



Testing Report



Equipment Under Test : 16 port Combo Free KVM Switch

Model Number : KCF1161S

Serial No. : KCF181S, KCB1161S, KCB181S

Applicant : Omnidirectional Control Technology Inc.

Address of Applicant : 8F-2, No.94, Pao-Chung Rd. Hsin-Tien
City, 231 Taipei Hsien, Taiwan R.O.C.

Matrix Test Laboratory
2F, No.146, Jian Yi Rd, Chung-Ho City,
Taipei Hsien, Taiwan, R.O.C.
TEL. : +886 02 2228-6610
FAX. : +886 02 2228-6580

Contents

1	General Description	4
1.1	Description of EUT	4
1.2	Tested Supporting Units	5
1.3	Block Diagram	9
1.4	Decision of Final Test Mode:	9
1.5	Test Facility	9
2	Conducted Emission Test	10
2.1	Test Instruments	10
2.2	Configuration of Instrument Setup	10
2.3	Conducted Limit	10
2.4	Set of Instrument	10
2.5	Test Configuration	11
2.6	Configuration of EUT	11
2.7	Test Result	11
3	Radiated Emission Test	13
3.1	Test Instruments	13
3.2	Configuration of Testing Setup	13
3.3	Radiated Limit	13
3.4	Set of Instrument	14
3.5	Test Configuration	14
3.6	Configuration of EUT	14
3.7	Test Result	14
4	Photographs of Test	16
4.1	Conducted Emission Test	16
4.2	Radiated Emission Test	17
5	Photographs of EUT	18
	Appendix 1 – Conducted Emission Test Waveform	22

Verification

Applicant:	Omnidirectional Control Technology Inc.
Manufacturer:	Omnidirectional Control Technology Inc.
EUT Description:	16 port Combo Free KVM Switch
Model No.:	KCF1161S
Serial No.:	KCF181S, KCB1161S, KCB181S
Sample received date :	2006-10-04
Test Standards :	<input checked="" type="checkbox"/> ANSI C63.4 & Part 15 B and CISPR 22 Class B

This report details the results of the testing carried out on one sample. The test results are contained in this test report and Matrix Test Laboratory assumes full responsibility for the accuracy and completeness of these Tests. This report shows the EUT is technically compliant with the ANSI C63.4 & Part 15 B and CISPR 22 Class B official requirements. This report applies to the above sample only and shall not be reproduced in part without written approval of Matrix Test Laboratory.

Documented: 
Date: 2006-10-13
Kay Wang/ ADM. Dept Staff

Test Engineer: 
Date: 2006-10-12
Louis Chou/ ENG. Dept. Staff

Approved: 
Date: 2006-10-13
Peter Chin/ Head of Laboratory

1 General Description

1.1 Description of EUT

Equipment Under Test	:	16 port Combo Free KVM Switch
Model Number	:	KCF1161S
Serial Number	:	KCF181S, KCB1161S, KCB181S
Applicant Address of Applicant	:	Omnidirectional Control Technology Inc. 8F-2, No.94, Pao-Chung Rd. Hsin-Tien City, 231 Taipei Hsien, Taiwan R.O.C.
Manufacturer Address of Manufacturer	:	Omnidirectional Control Technology Inc. 8F-2, No.94, Pao-Chung Rd. Hsin-Tien City, 231 Taipei Hsien, Taiwan R.O.C.
Power Supply	:	Switch Adaptor M/N: DSA-0101F-05A Input: 100~240VAC, 50/60HZ, 0.3A Output: +5Vdc, 2.0A, Power cord: <input type="checkbox"/> Shielded <input checked="" type="checkbox"/> Non-Shielded <input checked="" type="checkbox"/> Detachable, 1.8m <input type="checkbox"/> Un-detachable, <input checked="" type="checkbox"/> w/o ferrite core
Data Cable	:	<input checked="" type="checkbox"/> VGA Cable <input checked="" type="checkbox"/> Shielded <input type="checkbox"/> Non-Shielded <input checked="" type="checkbox"/> Detachable, 1.8m <input type="checkbox"/> Un-detachable, <input checked="" type="checkbox"/> w/o ferrite core
Description of EUT	:	Dimensions : 44.0 x 15.7 x 4.5 cm Weight : 1900g Intended function : The EUT is a KVM switch, which allows a user to control multiple computers from a single keyboard, mouse and monitor. Product Variant : The manufacturer declares that the difference between serial products is on the number of their connecting port. The product with maximum connecting port, 16 ports, has been selected as the main test model. Matrix only takes the responsibility to the test result of the main test sample.

1.2 Tested Supporting Units

1.2.1 Personal Computer

Model Number	:	HP Pavilion 743
Serial Number	:	TW25121617
EMC Approved	:	R33001
Manufacturer	:	HP
Switching Power Supply	:	BESTEC M/N :ATX-1956A S/N :BST ATX-1956A P1 EMC Approved :4902A033
3.5" Floppy Driver	:	MITSUMI M/N :D359M3D S/N :D359M3D4102002G17BY569 EMC Approved :62001002
Hard Disk Driver	:	SAMSONG M/N :SV4002H S/N :0412J1FTB55615 EMC Approved :D33020
CD-Rom	:	HP M/N :DVD WRITER 2000I S/N :N/A EMC Approved :N/A
Serial/Parallel Card	:	Within Mother Boar
Video Card	:	Within Mother Boar
Power Cord	:	Non-shielded, Detachable, 1.5m

PC02

Model Number	:	HP Pavilion 222
Serial Number	:	TWL33100KD
EMC Approved	:	R33001
Manufacturer	:	HP
Switching Power Supply	:	HIPRO M/N:HP-D2537F3H S/N:5187-1100 EMC Approved: D33036
3.5" Floppy Driver	:	N/A
Hard Disk Driver	:	Western Digital M/N: WD80BB-00DKAO S/N:WMAHL2771668 EMC Approved: D33015
CD-Rom	:	HP M/N:DVD WRITER 2000I S/N: N/A EMC Approved : N/A
VGA Card	:	M/N: A180DDR 64M S/N:L3090152690 L3090149683 EMC Approved: D33004
Serial/Parallel Card	:	Within Mother Boar
Video Card	:	Within Mother Boar

1.2.2 Monitor

Model Number	:	GC577
Serial Number	:	313FWNL2000031
EMC Approved	:	3902A178
Manufacturer	:	GENUINE
Data Cable	:	VGA CABLE Shielded, Un-detachable, 1.5m

1.2.3 PS2 Keyboard

Model Number	:	5181
Serial Number	:	BL24613476
EMC Approved	:	3892C981
Manufacturer	:	HP

1.2.4 PS2 Mouse

Model Number	:	MO42KOA
Serial Number	:	0306052598
EMC Approved	:	R41108
Manufacturer	:	HP

1.2.5 Printer

PR01

Model Number	:	HP DJ3820 PRINTER
Serial Number	:	CN33V180TR
EMC Approved	:	3912H007
Manufacturer	:	HP
Data Cable	:	N/A
Power Cord	:	Non-shielded, Detachable, 1.5M

PR02

Model Number	:	HP DJ3820 PRINTER
Serial Number	:	CN33V180TR
EMC Approved	:	3912H007
Manufacturer	:	HP
Data Cable	:	N/A
Power Cord	:	Non-shielded, Detachable, 1.5M

1.2.6

1.2.7

1.2.8

1.2.9

1.2.10 Modem*2

Model Number	:	50674
Serial Number	:	1142949
EMC Approved	:	FCC ID:C3KSS1
Manufacturer	:	Microsoft
Data Cable	:	RS232 Cable

1.2.11

1.2.12 USB Mouse

Model Number	:	50674
Serial Number	:	1142949
EMC Approved	:	FCC ID:C3KSS1
Manufacturer	:	Microsoft
Data Cable	:	RS232 Cable

1.2.13

1.2.14 USB Mouse

Model Number	:	828 U+P(GM3S-668)
Serial Number	:	668200301023205
EMC Approved	:	3902C180
Manufacturer	:	Genuine
Data Cable	:	USB CABLE Non-shielded, Un-detachable, 1.5m

1.2.15 RS232 Mouse

Model Number	:	2846
Serial Number	:	QL24618469
EMC Approved	:	3892C947
Manufacturer	:	HP

1.3 Block Diagram

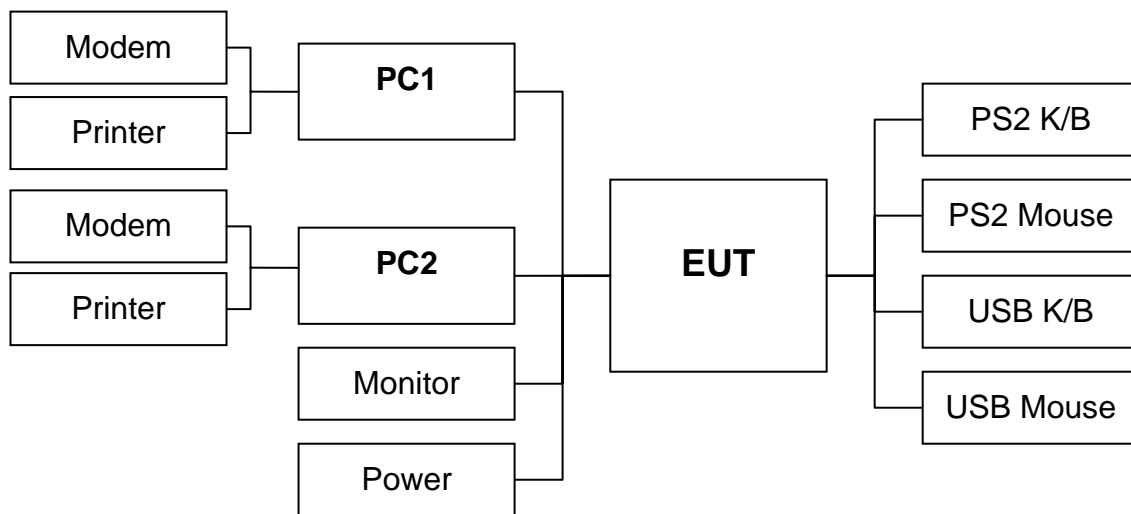

1.4 Decision of Final Test Mode:

Winfcc mode (1024x768)

1.5 Test Facility

Site Description	:	All tests are completed by Matrix Test Laboratory. Radiated emission is performed at HongAn's open-site.
Name of Firm	:	Matrix Test Laboratory
Site Location	:	2F, No 146, Jian Yi Rd, Chung-Ho City, Taipei Hsien, Taiwan, R.O.C.

1.5.1 Test Methodology

Both conducted and Radiated Emission Test were performed according to the procedures in ANSI C63.4-1992 & FCC PART 15 B and CISPR 22 Class B : 1997 / A1: 2000. Radiated Emission Test was performed at 10 meters distance from antenna to EUT.

2 Conducted Emission Test

2.1 Test Instruments

Instrument	Manufacturer	Model	Serial No.	Date of Calibration
EMI RECEIVER	AFJ	ER 55 CR/2.8	55309930144	2005-07-26
L.I.S.N.	Mess Tec	NNB-2/16Z	03/1006	2005-03-07
Pulse Limiter	Mess Tec	PL10	N/A	2005-07-27
RF CABLE	N/A	N/A	N/A	2005-03-14

Note: All Test Instruments upon which need to be calibrated are within calibration period of 1 year.

2.2 Configuration of Instrument Setup

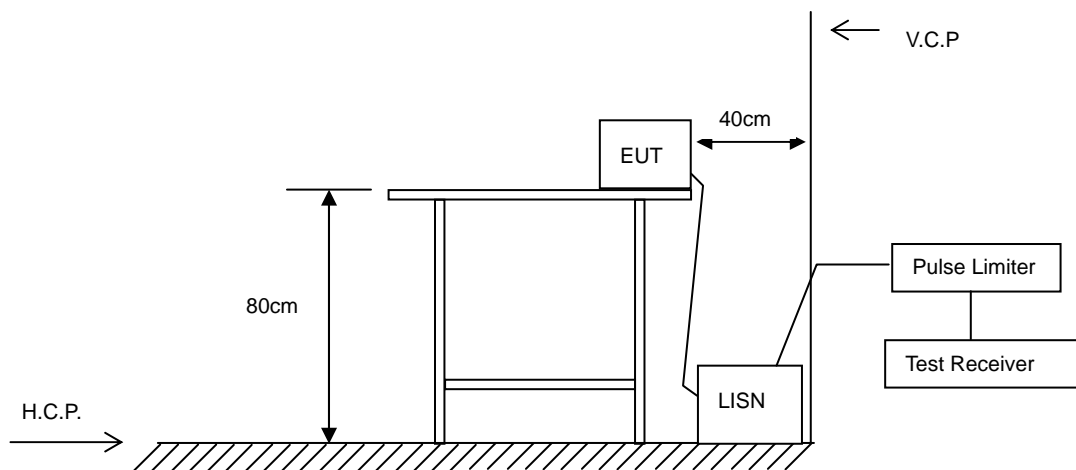

2.3 Conducted Limit

CISPR 22 / FCC Part 15 B

Frequency (MHz)	<input type="checkbox"/> Class A		<input checked="" type="checkbox"/> Class B	
	Q.P. (Quasi-Peak)	A.V. (Average)	Q.P. (Quasi-Peak)	A.V. (Average)
0.15 ~ 0.50	79	66	66 to 56	56 to 46
0.50 ~ 5.0	73	60	56	46
5.0 ~ 30	73	60	60	50

2.4 Set of Instrument

- 2.4.1 The EMI test receiver frequency range set from 150 KHz to 30 MHz.
- 2.4.2 The EMI test receiver bandwidth set at 9kHz.
- 2.4.3 The EMI test receiver detector set as Quasi-Peak (Q.P.) and Average (AV).

2.5 Test Configuration

- 2.5.1 The EUT was placed on a non-conductive table whose total height equaled 80cm and vertical conducting plane located 40cm to the rear of the EUT.
- 2.5.2 The EUT was connected to the main power through Line Impedance Stabilization Networks (LISN). This setup provided a 50ohm/50 μ H coupling impedance for the measuring equipment. The auxiliary equipment was also connected to the main power through a LISN that provided a 50ohm/50 μ H coupling impedance with 50ohm termination. (Refer to the block diagram of the test setup and photographs.)
- 2.5.3 The conducted disturbance was measured between the phase lead and the reference ground, and between the neutral lead and reference ground. The initial testing identified the frequency that has the highest disturbance relative to the limit while operating the EUT in typical modes of operation and cable positions in a test setup representative of typical system configuration.
- 2.5.4 The identification of the frequency of highest disturbance with respect to the limit was found by investigating disturbances at a number of significant frequencies. The probable frequency of maximum disturbance had been found and that the associated cable and EUT configuration and mode of operation had been identified.

2.6 Configuration of EUT

- 2.6.1 Setup the EUT and peripheral as shown in section 1.3.
- 2.6.2 Turn on the power of all equipment.
- 2.6.3 Activate the Winfcc mode (1024x768).
- 2.6.4 Measure the Line phase and record value.
- 2.6.5 Change into Neutral phase then measure and record value.

2.7 Test Result

PASS.

The final tests data are shown on following pages. The test waveforms are shown on Appendix 1.

Power Line Conducted Test Data

Date of Tested : 2006-10-11 Power Line : Line
 Temperature : 25 Humidity : 40%
 Test Mode : Winfcc mode (1024x768)

Frequency (MHz)	Factor (dB)	Reading (dBuV)		Measurement (dBuV)		Limits (dBuV)		Margin (dB)	
		Quasi-Peak	Average	Quasi-Peak	Average	Quasi-Peak	Average	Quasi-Peak	Average
0.177	0.04	58.09	46.60	58.13	46.64	64.63	54.63	-6.50	-7.99
0.213	0.04	45.60	10.04	45.64	10.08	63.09	53.09	-17.45	-43.01
0.339	0.04	47.03	31.00	47.07	31.04	59.23	49.23	-12.16	-18.19
0.510	0.05	46.67	27.67	46.72	27.72	56.00	46.00	-9.28	-18.28
0.690	0.06	46.16	24.44	46.22	24.50	56.00	46.00	-9.78	-21.50
0.852	0.06	45.19	25.93	45.25	25.99	56.00	46.00	-10.75	-20.01

Remark:

1. All readings are Quasi-Peak and Average values.
2. Factor = Insertion Loss + Cable Loss
3. “**” Means emission level un-detectable.
4. “--” Means do not need detect.

Power Line Conducted Test Data

Date of Tested : 2006-10-11 Power Line : Neutral
 Temperature : 25 Humidity : 40%
 Test Mode : Winfcc mode (1024x768)

Frequency (MHz)	Factor (dB)	Reading (dBuV)		Measurement (dBuV)		Limits (dBuV)		Margin (dB)	
		Quasi-Peak	Average	Quasi-Peak	Average	Quasi-Peak	Average	Quasi-Peak	Average
0.177	0.04	57.69	46.55	57.73	46.59	64.63	54.63	-6.90	-8.04
0.690	0.06	48.11	24.88	48.17	24.94	56.00	46.00	-7.83	-21.06
0.897	0.07	48.69	22.32	48.76	22.39	56.00	46.00	-7.24	-23.61
1.671	0.07	48.67	24.90	48.74	24.97	56.00	46.00	-7.26	-21.03
1.941	0.07	49.37	26.67	49.44	26.74	56.00	46.00	-6.56	-19.26
3.021	0.11	49.09	26.04	49.20	26.15	56.00	46.00	-6.80	-19.85

Remark:

1. All readings are Quasi-Peak and Average values.
2. Factor = Insertion Loss + Cable Loss
3. “**” Means emission level un-detectable.
4. “--” Means do not need detect.

3 Radiated Emission Test

3.1 Test Instruments

Instrument	Manufacturer	Model	Serial No.	Date of Calibration
SPECTURM ANALZYER	HP	8595E	3829A03763	2005-07-19
Antenna	FRANKONIA	BTA-H	030001H	2005-03-25
Pre-Amplifier	Schaffner	CPA9231A	N/A	2005-04-24
RF Cable	MIYAZAKI	8D-F8	N/A	2005-04-30
EMI Test Receiver	Rohde & Schwarz	ESI 07	N/A	2005-03-25

Note: All Test Instruments upon which need to be calibrated are within calibration period of 1 year.

3.2 Configuration of Testing Setup

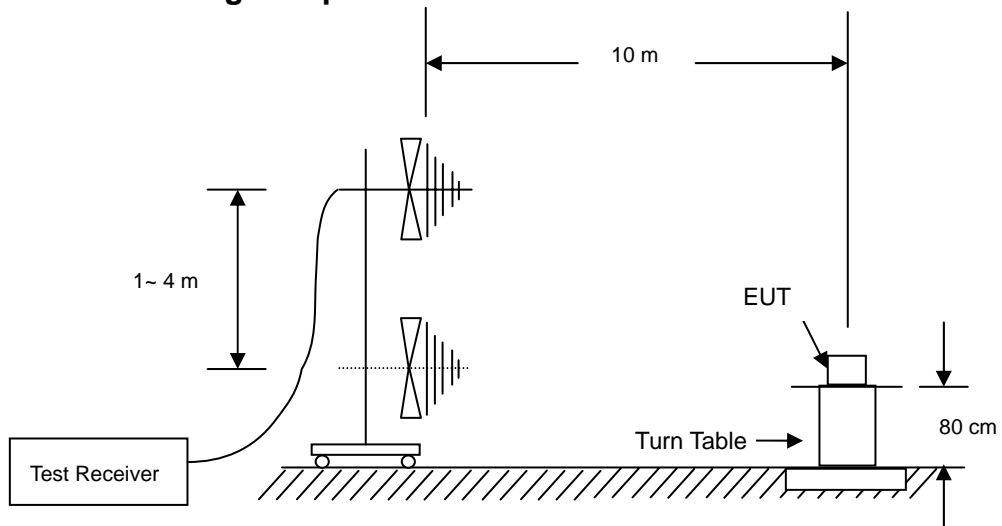

3.3 Radiated Limit

FCC Part 15

Frequency (MHz)	<input type="checkbox"/> Class A (10m)		<input type="checkbox"/> Class B (3m)	
	Field Strength (uV)	Quasi-Peak (dBuV)	Field Strength (uV)	Quasi-Peak (dBuV)
30 ~ 88	90	39.08	100	40.00
88 ~ 216	150	43.52	150	43.52
216 ~ 960	210	46.44	200	46.02
960 above	300	49.54	500	53.98

CISPR 22

Frequency (MHz)	<input type="checkbox"/> Class A	<input checked="" type="checkbox"/> Class B
	Quasi-Peak (dBuV)	Quasi-Peak (dBuV)
30 ~ 230	40.0	30.0
230 ~ 1000	47.0	37.0

3.4 Set of Instrument

- 3.4.1 The EMI test receiver frequency range set from 30 MHz to 1000 MHz.
- 3.4.2 The EMI test receiver bandwidth set at 120 kHz.
- 3.4.3 The EMI test receiver detector set as Quasi-Peak (Q.P.).

3.5 Test Configuration

- 3.5.1 The EUT was placed on a non-conductive table whose total height equaled 80cm. The turntable can rotate 360 degree to determine the position of the maximum emission level.
- 3.5.2 The EUT was set 10 meters away from the receiving antenna that was mounted on a non-conductive mast. The antenna can move up and down between 1 to 4 meters to find out the maximum emission level.
- 3.5.3 The initial testing identified the frequency that has the highest disturbance relative to the limit while operating the EUT in typical modes of operation and cable positions in a test setup representative of typical system configuration.
- 3.5.4 The identification of the frequency of highest emission with respect to the limit was found by investigating emissions at a number of significant frequencies. The probable frequency of maximum emission had been found and that the associated cable and EUT configuration and mode of operation had been identified.

3.6 Configuration of EUT

- 3.6.1 Setup the EUT and peripheral as shown in section 1.3.
- 3.6.2 Turn on the power of all equipment.
- 3.6.3 Activate the Winfcc mode (1024x768).
- 3.6.4 Measure the horizontal polarization and record the value.
- 3.6.5 Change into vertical polarization measure and record the value.

3.7 Test Result

PASS.

The final tests data are shown on following pages.

Radiated Emission Test Data

Date of Tested : 2006-10-12 Polarization : Horizontal
 Temperature : 25 Humidity : 50%
 Test Mode : Winfcc mode (1024x768)

Frequency (MHz)	Factor (dB)	Meter Reading (dBuV)	Emission Level (dBuV)	Limits (dBuV/m)	Margin (dB)
172.72	8.91	15.29	24.2	30	-5.8
303.34	13.29	18.51	31.8	37	-5.2
396.2	15.44	15.56	31	37	-6
402.52	15.92	15.48	31.4	37	-5.6
666.18	19.66	14.04	33.7	37	-3.3
753.27	21.47	9.53	31	37	-6

Remark:

- All readings are Quasi-Peak values.
- The worst emission was detected at 666.18 MHz with corrected signal level of 33.7 dBuV (limit is 37 dBuV) when the antenna was at horizontal polarization and was at 3 m high and the turntable was at 159°.

Radiated Emission Test Data

Date of Tested : 2006-10-12 Polarization : Vertical
 Temperature : 25 Humidity : 50%
 Test Mode : Winfcc mode (1024x768)

Frequency (MHz)	Factor (dB)	Meter Reading (dBuV)	Emission Level (dBuV)	Limits (dBuV/m)	Margin (dB)
83.22	8.37	18.73	27.1	30	-2.9
114.66	8.49	17.41	25.9	30	-4.1
213.84	13.57	16.13	29.7	30	-0.3
666.18	19.66	14.34	34	37	-3
801.65	22.2	9.1	31.3	37	-5.7
813.74	22.46	9.54	32	37	-5

Remark:

- All readings are Quasi-Peak values.
- The worst emission was detected at 213.84 MHz with corrected signal level of 29.7 dBuV (limit is 30 dBuV) when the antenna was at vertical polarization and was at 1 m high and the turntable was at 217°.

4 Photographs of Test

4.1 Conducted Emission Test



Front View

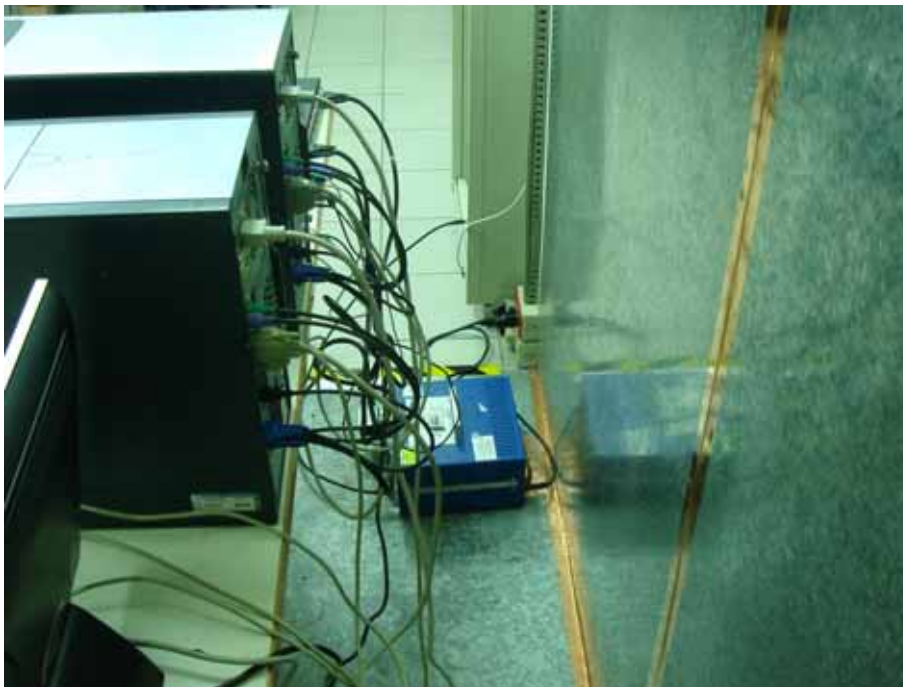

Rear View

4.2 Radiated Emission Test



Front View



Rear view

5 Photographs of EUT



Front View of EUT



Rear View of EUT



Inside view of EUT



Front view of EUT's PCB1-1

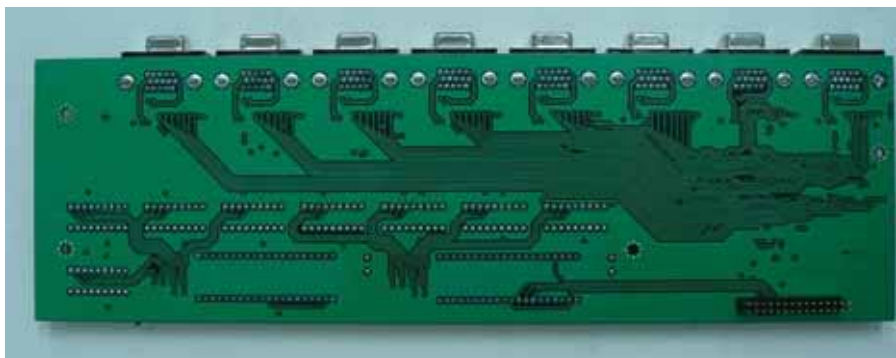

Rear view of EUT's PCB 1-2



Front view of EUT's PCB 2-1

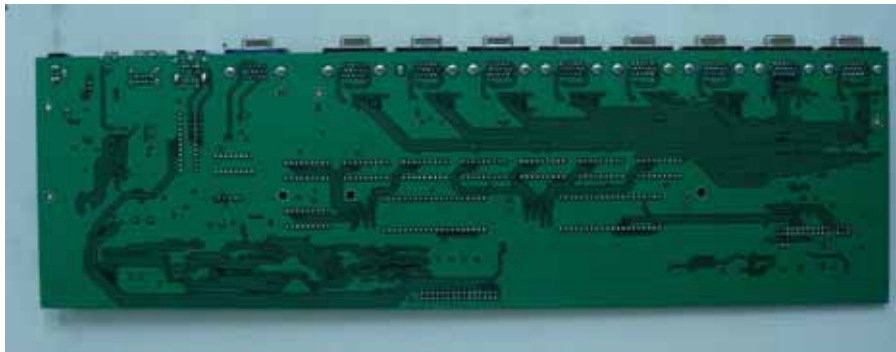

Rear view of EUT's PCB 2-2



Front view of EUT's PCB 3-1

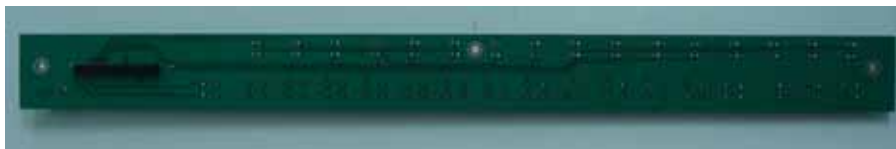

Rear view of EUT's PCB 3-2



View of EUT's VGA Cable



View of EUT's Adaptor

Appendix 1 – Conducted Emission Test Waveform

A1.1 Mode : Winfcc mode(1024x768)

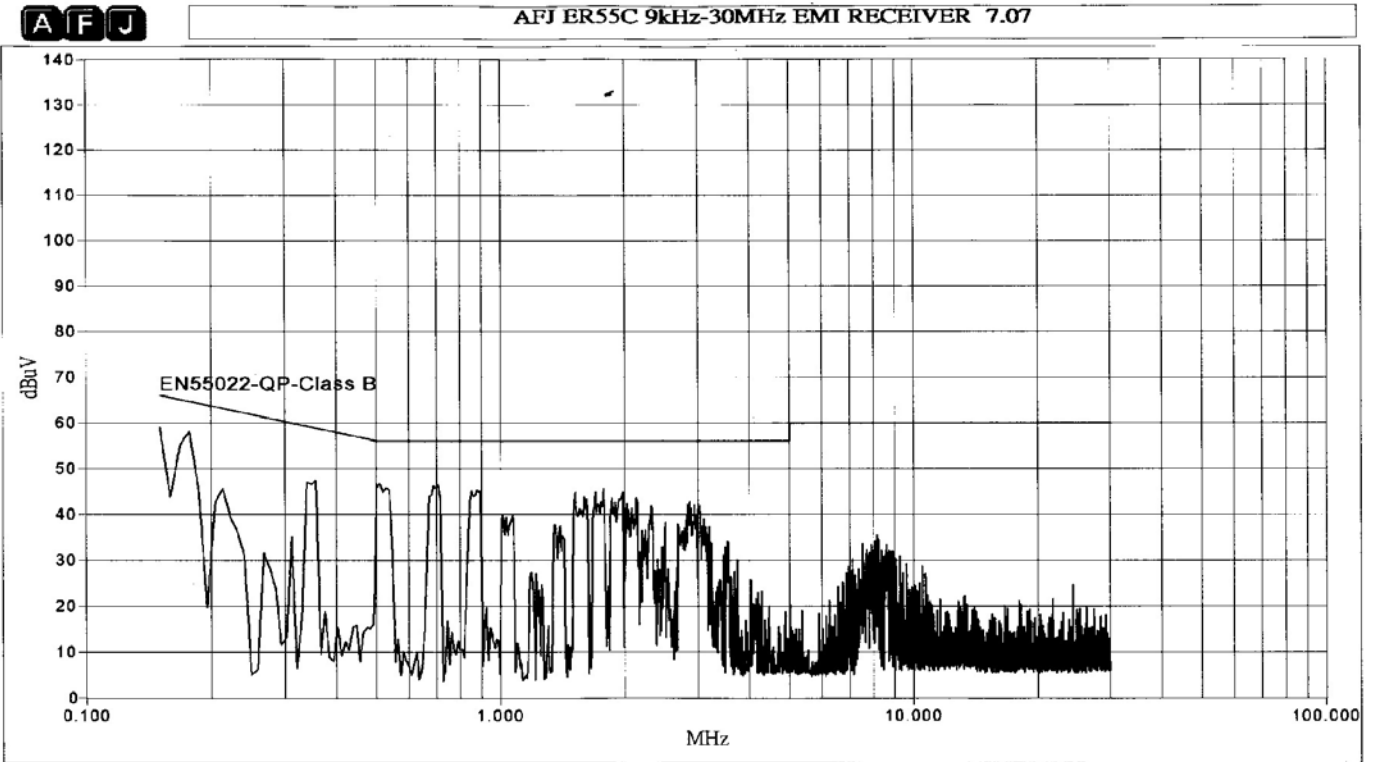

Line

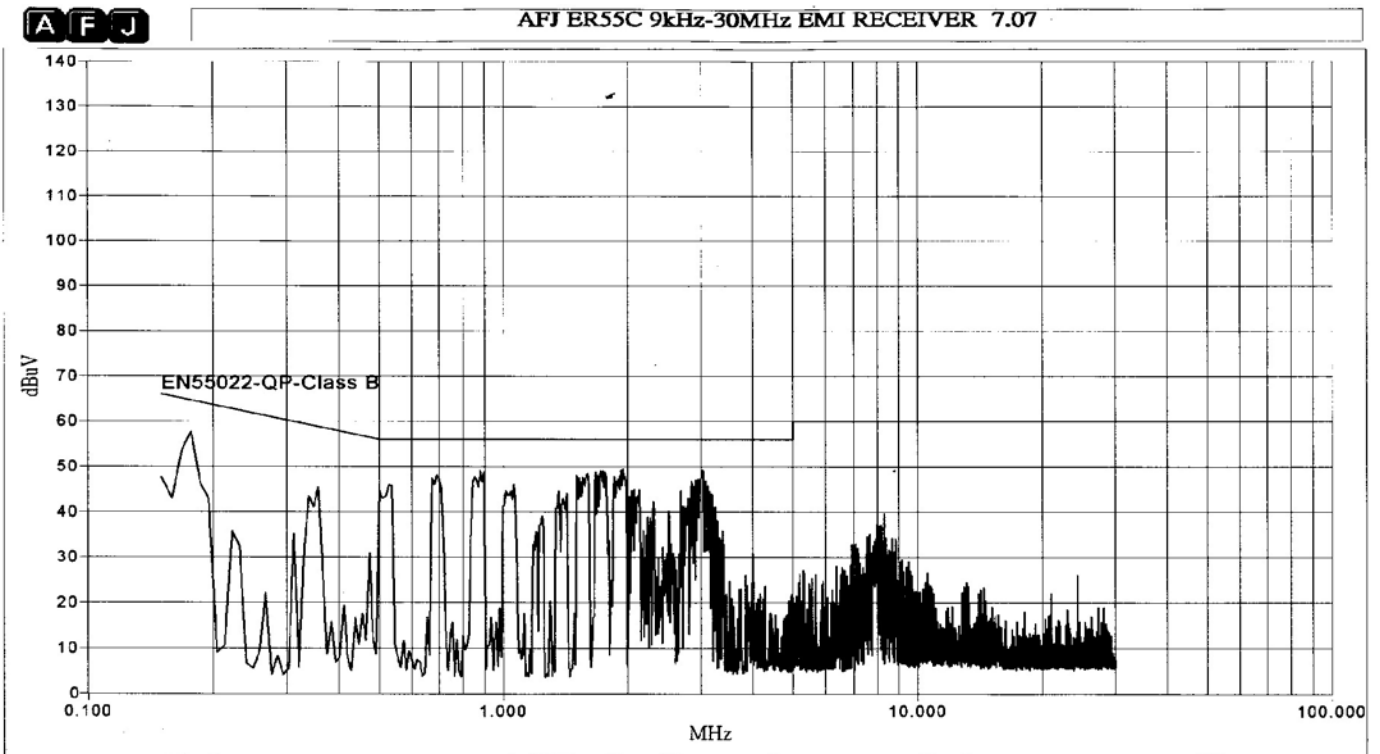

Neutral