



EMC Testing Report



Equipment Under Test : 16 port Combo Free KVM Switch

Model Number : KCF1161S

Serial No. : KCF181S, KCB1161S, KCB181S

Applicant : Omnidirectional Control Technology Inc.

Address of Applicant : 8F-2, No.94, Pao-Chung Rd. Hsin-Tien
City, 231 Taipei Hsien, Taiwan R.O.C.

Matrix Test Laboratory
2F, No.146, Jian Yi Rd, Chung-Ho City,
Taipei Hsien, Taiwan, R.O.C.
TEL. : +886 02 2228-6610
FAX. : +886 02 2228-6580

Contents

1	General Description	6
1.1	Description of EUT	6
1.2	Tested Supporting Units	7
1.3	Block Diagram	11
1.4	Decision of Final Test Mode	11
1.5	Immunity Performance Criterion	11
1.6	Test Facility	11
2	Conducted Emission Test	12
2.1	Test Instruments	12
2.2	Configuration of Instrument Setup	12
2.3	Conducted Limit	12
2.4	Set of Instrument	12
2.5	Test Configuration	13
2.6	Configuration of EUT	13
2.7	Test Result	13
3	Radiated Emission Test	15
3.1	Test Instruments	15
3.2	Configuration of Instrument Setup	15
3.3	Radiated Limit	15
3.4	Set of Instrument	15
3.5	Test Configuration	16
3.6	Configuration of EUT	16
3.7	Test Result	16
4	Harmonic Current Emission Measurement	18
4.1	Instrument	18
4.2	Configuration of Instrument Setup	18
4.3	EUT Operation Condition	18
4.4	Test Limit	18
4.5	Test Configuration	19
4.6	Configuration of EUT	19
4.7	Test Result	19
5	Voltage Fluctuations and Flicker Measurement	21
5.1	Instrument	21
5.2	Configuration of Instrument Setup	21
5.3	EUT Operation Condition	21

5.4	Test Limit	21
5.5	Test Configuration	22
5.6	Configuration of EUT	22
5.7	Test Result	22
6	Electrostatic Discharge Immunity Test	24
6.1	Instrument	24
6.2	Configuration of Instrument Setup	24
6.3	Test Levels	24
6.4	Test Configuration	25
6.5	Configuration of EUT	25
6.6	Test Requirement	25
6.7	Test Result	26
7	Radio-frequency, Electromagnetic field Immunity Test	27
7.1	Instrument	27
7.2	Configuration of Instrument Setup	27
7.3	Test Level	27
7.4	Test Configuration	28
7.5	Configuration of EUT	28
7.6	Test Result	28
8	Electrical Fast Transient/Burst Immunity Test	29
8.1	Instrument	29
8.2	Configuration of Instrument Setup	29
8.3	Test Level	29
8.4	Test Configuration	29
8.5	Configuration of EUT	30
8.6	Test Result	30
9	Surge Immunity Test	31
9.1	Instrument	31
9.2	Configuration of Instrument Setup	31
9.3	Test Level	31
9.4	Test Configuration	31
9.5	Configuration of EUT	32
9.6	Test Result	32
10	Radio-frequency, Conducted Disturbances Immunity Test	33
10.1	Instrument	33
10.2	Configuration of Instrument Setup	33
10.3	Test Level	33
10.4	Test Configuration	33

10.5	Configuration of EUT	34
10.6	Test Result	34
11	Voltage Dips, Short Interruptions Immunity Test	35
11.1	Instrument	35
11.2	Configuration of Instrument Setup	35
11.3	Test Level	35
11.4	Test Configuration	35
11.5	Configuration of EUT	36
11.6	Test Result	36
12	Photographs of Test	37
12.1	Power Line Conducted Test	37
12.2	Radiated Emission Test	38
12.3	Harmonic current & Voltage Fluctuations and Flicker Measurement	39
12.4	Electrostatic Discharge Immunity Test	39
12.5	Electrical Fast Transient/Burst Immunity Test	40
12.6	Surge immunity Test	40
12.7	Radio-frequency, Conducted Disturbances Immunity Test	41
12.8	Voltage Dips, Short Interruptions Immunity Test	41
13	Photographs of EUT	42
14	Photographs of ESD Test Point	46
Appendix 1	- Conducted Emission Test Waveform	48
A1.1	Mode : Winfcc mode(1024×768)	48

Verification

Applicant : Omnidirectional Control Technology Inc.
Manufacturer : Omnidirectional Control Technology Inc.
Equipment Under Test : 16 port Combo Free KVM Switch
Model No. : KCF1161S
Serial No. : KCF181S, KCB1161S,KCB181S
Sample received date : 2006-10-04

Test Standards :

Emission:	Immunity:
<input checked="" type="checkbox"/> EN 55022:1998 Class B A1:2000 A2:2003	<input checked="" type="checkbox"/> EN 55024:1998 A1:2001 A2:2003
<input checked="" type="checkbox"/> EN 61000-3-2:2000 A2: 2005	<input checked="" type="checkbox"/> EN 61000-4-2
<input checked="" type="checkbox"/> EN 61000-3-3:1995 A1:2001	<input checked="" type="checkbox"/> EN 61000-4-3
	<input checked="" type="checkbox"/> EN 61000-4-4
	<input checked="" type="checkbox"/> EN 61000-4-5
	<input checked="" type="checkbox"/> EN 61000-4-6
	<input checked="" type="checkbox"/> EN 61000-4-11

Remark:

This report details the results of the testing carried out on one sample .The emission levels emanate from the device and the device endure and its performance criterion. This report shows the EUT is technically compliant with the EN 55022 and EN 55024 official requirements. This report applies to the above sample only and shall not be reproduced in part without written approval of Matrix Test Laboratory.

Kay Wang

Documented: _____ **Date:** 2006-10-13
 Kay Wang/ ADM. Dept Staff

Louis chou.

Test Engineer: _____ **Date:** 2006-10-12
 Louis Chou/ ENG. Dept. Staff

Peter Chin

Approved: _____ **Date:** 2006-10-13
 Peter Chin/ Head of Laboratory

1 General Description

1.1 Description of EUT

Equipment Under Test	:	16 port Combo Free KVM Switch
Model Number	:	KCF1161S
Serial Number	:	KCF181S, KCB1161S, KCB181S
Applicant Address of Applicant	:	Omnidirectional Control Technology Inc. 8F-2, No.94, Pao-Chung Rd. Hsin-Tien City, 231 Taipei Hsien, Taiwan R.O.C.
Manufacturer Address of Manufacturer	:	Omnidirectional Control Technology Inc. 8F-2, No.94, Pao-Chung Rd. Hsin-Tien City, 231 Taipei Hsien, Taiwan R.O.C.
Power Supply	:	Switch Adaptor M/N: DSA-0101F-05A Input: 100~240VAC, 50/60HZ, 0.3A Output: +5Vdc, 2.0A, Power cord: <input type="checkbox"/> Shielded <input checked="" type="checkbox"/> Non-Shielded <input checked="" type="checkbox"/> Detachable, 1.8m <input type="checkbox"/> Un-detachable, <input checked="" type="checkbox"/> w/o ferrite core
Data Cable	:	<input checked="" type="checkbox"/> VGA Cable <input checked="" type="checkbox"/> Shielded <input type="checkbox"/> Non-Shielded <input checked="" type="checkbox"/> Detachable, 1.8m <input type="checkbox"/> Un-detachable, <input checked="" type="checkbox"/> w/o ferrite core
Description of EUT	:	Dimensions : 44.0 x 15.7 x 4.5 cm Weight : 1900g Intended function : The EUT is a KVM switch, which allows a user to control multiple computers from a single keyboard, mouse and monitor. Product Variant : The manufacturer declares that the difference between serial products is on the number of their connecting port. The product with maximum connecting port, 16 ports, has been selected as the main test model. Matrix only takes the responsibility to the test result of the main test sample.

1.2 Tested Supporting Units

1.2.1 Personal Computer

PC01

Model Number	:	HP Pavilion 743
Serial Number	:	TW25121617
EMC Approved	:	R33001
Manufacturer	:	HP
Switching Power Supply	:	BESTEC M/N :ATX-1956A S/N :BST ATX-1956A P1 EMC Approved :4902A033
3.5" Floppy Driver	:	MITSUMI M/N :D359M3D S/N :D359M3D4102002G17BY569 EMC Approved :62001002
Hard Disk Driver	:	SAMSONG M/N :SV4002H S/N :0412J1FTB55615 EMC Approved :D33020
CD-Rom	:	HP M/N :DVD WRITER 2000I S/N :N/A EMC Approved :N/A
Serial/Parallel Card	:	Within Mother Boar
Video Card	:	Within Mother Boar
Power Cord	:	Non-shielded, Detachable, 1.5m

PC02

Model Number	:	HP Pavilion 222
Serial Number	:	TWL33100KD
EMC Approved	:	R33001
Manufacturer	:	HP
Switching Power Supply	:	HIPRO M/N:HP-D2537F3H S/N:5187-1100 EMC Approved: D33036
3.5" Floppy Driver	:	N/A
Hard Disk Driver	:	Western Digital M/N: WD80BB-00DKAO S/N:WMAHL2771668 EMC Approved: D33015
CD-Rom	:	HP M/N:DVD WRITER 2000I S/N: N/A EMC Approved : N/A
VGA Card	:	M/N: A180DDR 64M S/N:L3090152690 L3090149683 EMC Approved: D33004
Serial/Parallel Card	:	Within Mother Boar
Video Card	:	Within Mother Boar

1.2.2 Monitor

Model Number	:	GC577
Serial Number	:	313FWNL2000031
EMC Approved	:	3902A178
Manufacturer	:	GENUINE
Data Cable	:	VGA CABLE Shielded, Un-detachable, 1.5m

1.2.3 PS2 Keyboard

Model Number	:	5181
Serial Number	:	BL24613476
EMC Approved	:	3892C981
Manufacturer	:	HP

1.2.4 PS2 Mouse

Model Number	:	MO42KOA
Serial Number	:	0306052598
EMC Approved	:	R41108
Manufacturer	:	HP

1.2.5 Printer

PR01

Model Number	:	HP DJ3820 PRINTER
Serial Number	:	CN33V180TR
EMC Approved	:	3912H007
Manufacturer	:	HP
Data Cable	:	N/A
Power Cord	:	Non-shielded, Detachable, 1.5M

PR02

Model Number	:	HP DJ3820 PRINTER
Serial Number	:	CN33V180TR
EMC Approved	:	3912H007
Manufacturer	:	HP
Data Cable	:	N/A
Power Cord	:	Non-shielded, Detachable, 1.5M

1.2.6 Modem*2

Model Number	:	MD-56K
Serial Number	:	1234A036998
EMC Approved	:	3882B582
Manufacturer	:	LEMEL
Data Cable	:	N/A
Power Adapter	:	CLASS 2 POWER SUPPLY

1.2.7 USB Mouse

Model Number	:	828 U+P(GM3S-668)
Serial Number	:	668200301023205
EMC Approved	:	3902C180
Manufacturer	:	Genuine
Data Cable	:	USB CABLE Non-shielded, Un-detachable, 1.5m

1.2.8 USB Keyboard

Model Number	:	2846
Serial Number	:	QL24618469
EMC Approved	:	3892C947
Manufacturer	:	HP

1.3 Block Diagram

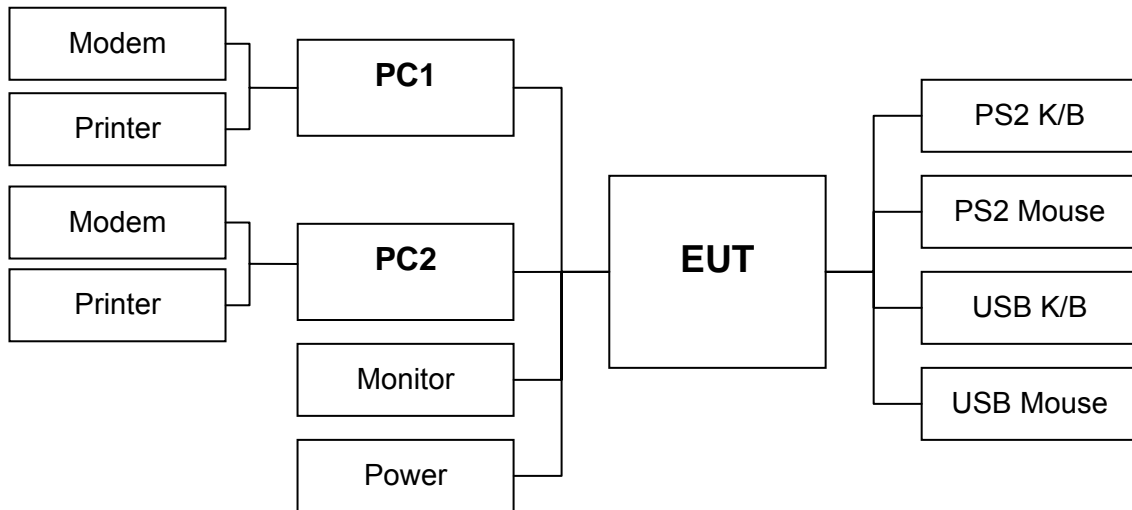

1.4 Decision of Final Test Mode

Winfcc mode (1024x768)

1.5 Immunity Performance Criterion

Criterion	Test description
A	The equipment shall continue to operate as intended without operator intervention, degradation of performance or loss of function is allowed below a performance level specified by the manufacturer when the equipment is used as intended.
B	After the test, the equipment shall continue to operate as intended without operator intervention, degradation of performance or loss of function is allowed.
C	Loss of function is allowed, provided the function is self-recoverable, or can be restored by the operation of controls by the user in accordance with the manufacturer's instructions.

1.6 Test Facility

Site Description	:	All tests are completed by Matrix Test Laboratory. Radiated emission is performed at HongAn's open-site.
Name of Firm	:	Matrix Test Laboratory
Site Location	:	2F, No 146, Jian Yi Rd, Chung-Ho City, Taipei Hsien, Taiwan, R.O.C.

1.6.1 Methods and Procedures

Both conducted and Radiated Emission Test was performed according to the procedures in EN 55022. Radiated Emission Test was performed at 10 meters distance from antenna to EUT. All immunity tests were performed according to the procedures in EN 55024

2 Conducted Emission Test

2.1 Test Instruments

Instrument	Manufacturer	Model	Serial No.	Date of Calibration
EMI RECEIVER	AFJ	ER 55 CR/2.8	55309930144	2005-07-26
L.I.S.N.	Mess Tec	NNB-2/16Z	03/1006	2005-03-07
Pulse Limiter	Mess Tec	PL10	N/A	2005-07-27
RF CABLE	N/A	N/A	N/A	2005-03-14

Note: All instrument upon which need to calibrated are with calibration period of 1 year.

2.2 Configuration of Instrument Setup

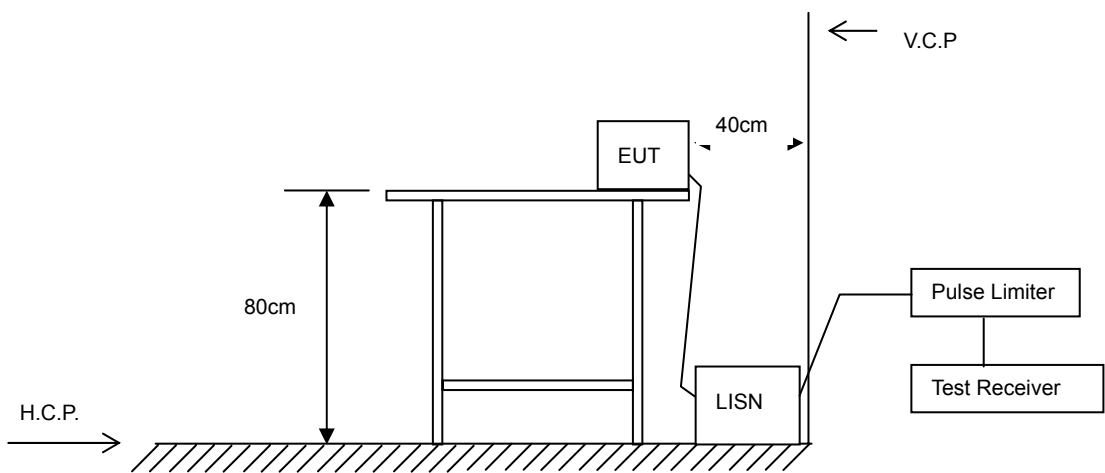

2.3 Conducted Limit

EN 55022:2003

Frequency (MHz)	<input type="checkbox"/> Class A		<input checked="" type="checkbox"/> Class B	
	Q.P. (Quasi-Peak)	A.V. (Average)	Q.P. (Quasi-Peak)	A.V. (Average)
0.15 ~ 0.50	79	66	66 to 56	56 to 46
0.50 ~ 5.0	73	60	56	46
5.0 ~ 30	73	60	60	50

2.4 Set of Instrument

- 2.4.1 The EMI test receiver frequency range set from 150 KHz to 30 MHz.
- 2.4.2 The EMI test receiver bandwidth set at 9kHz.
- 2.4.3 The EMI test receiver detector set as Quasi-Peak (Q.P.) and Average (AV).

2.5 Test Configuration

- 2.5.1 The EUT was placed on a non-conductive table whose total height equaled 80cm and vertical conducting plane located 40cm to the rear of the EUT.
- 2.5.2 The EUT was connected to the main power through Line Impedance Stabilization Networks . This setup provided a 50ohm /50 μ H coupling impedance for the measuring equipment. The auxiliary equipment was also connected to the main power through a LISN that provided a 50ohm/50 μ H coupling impedance with 50ohm termination.
- 2.5.3 The conducted disturbance was measured between the phase lead and the reference ground, and between the neutral lead and reference ground. The initial testing identified the frequency that has the highest disturbance relative to the limit while operating the EUT in typical modes of operation and cable positions in a test setup representative of typical system configuration.
- 2.5.4 The identification of the frequency of highest disturbance with respect to the limit was found by investigating disturbances at a number of significant frequencies. The probable frequency of maximum disturbance had been found and that the associated cable and EUT configuration and mode of operation had been identified.

2.6 Configuration of EUT

- 2.6.1 Setup the EUT and simulate as shown section 1.3.
- 2.6.2 Turn on the power of all equipment.
- 2.6.3 Activate the Winfcc mode (1024x768).
- 2.6.4 Measure the Line phase and record value.
- 2.6.5 Change into Neutral phase and record value.

2.7 Test Result

PASS.

The final tests data as shown on following page. The other preliminary tests data as shown on Appendix 1.

Conducted Emission Test Data

Date of Tested : 2006-10-11 Power Line : Line
 Temperature : 25 Humidity : 40%
 Test Mode : Winfcc mode (1024x768)

Frequency (MHz)	Factor (dB)	Reading (dBuV)		Measurement (dBuV)		Limits (dBuV)		Margin (dB)	
		Quasi-Peak	Average	Quasi-Peak	Average	Quasi-Peak	Average	Quasi-Peak	Average
0.177	0.04	58.09	46.60	58.13	46.64	64.63	54.63	-6.50	-7.99
0.213	0.04	45.60	10.04	45.64	10.08	63.09	53.09	-17.45	-43.01
0.339	0.04	47.03	31.00	47.07	31.04	59.23	49.23	-12.16	-18.19
0.510	0.05	46.67	27.67	46.72	27.72	56.00	46.00	-9.28	-18.28
0.690	0.06	46.16	24.44	46.22	24.50	56.00	46.00	-9.78	-21.50
0.852	0.06	45.19	25.93	45.25	25.99	56.00	46.00	-10.75	-20.01

Remark :

1. All readings are Quasi-Peak and Average values.
2. Factor = Insertion Loss + Cable Loss

Conducted Emission Test Data

Date of Tested : 2006-10-11 Power Line : Neutral
 Temperature : 25 Humidity : 40%
 Test Mode : Winfcc mode (1024x768)

Frequency (MHz)	Factor (dB)	Reading (dBuV)		Measurement (dBuV)		Limits (dBuV)		Margin (dB)	
		Quasi-Peak	Average	Quasi-Peak	Average	Quasi-Peak	Average	Quasi-Peak	Average
0.177	0.04	57.69	46.55	57.73	46.59	64.63	54.63	-6.90	-8.04
0.690	0.06	48.11	24.88	48.17	24.94	56.00	46.00	-7.83	-21.06
0.897	0.07	48.69	22.32	48.76	22.39	56.00	46.00	-7.24	-23.61
1.671	0.07	48.67	24.90	48.74	24.97	56.00	46.00	-7.26	-21.03
1.941	0.07	49.37	26.67	49.44	26.74	56.00	46.00	-6.56	-19.26
3.021	0.11	49.09	26.04	49.20	26.15	56.00	46.00	-6.80	-19.85

Remark :

1. All readings are Quasi-Peak and Average values.
2. Factor = Insertion Loss + Cable Loss.

3 Radiated Emission Test

3.1 Test Instruments

Instrument	Manufacturer	Model	Serial No.	Date of Calibration
SPECTURM ANALZYER	HP	8595E	3829A03763	2005-07-19
Antenna	FRANKONIA	BTA-H	030001H	2005-03-25
Pre-Amplifier	Schaffner	CPA9231A	N/A	2005-04-24
RF Cable	MIYAZAKI	8D-F8	N/A	2005-04-30
EMI RECEIVER	AFJ	ER 55 CR/2.8	55309930144	2005-07-26

Note: All instrument upon which need to calibrated are with calibration period of 1 year.

3.2 Configuration of Instrument Setup

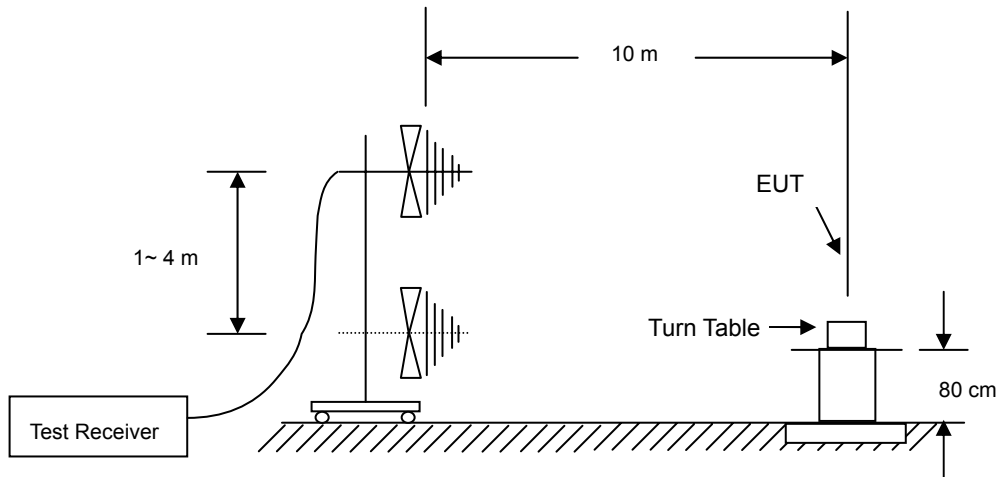

3.3 Radiated Limit

EN 55022:2003

Frequency (MHz)	<input type="checkbox"/> Class A	<input checked="" type="checkbox"/> Class B
	Quasi-Peak (dBuV/m)	Quasi-Peak (dBuV/m)
30 ~ 230	40.0	30.0
230 ~ 1000	47.0	37.0

3.4 Set of Instrument

- 3.4.1 The EMI test receiver frequency range set from 30 MHz to 1000 MHz.
- 3.4.2 The EMI test receiver bandwidth set at 120 kHz.
- 3.4.3 The EMI test receiver detector set as Quasi-Peak (Q.P.).

3.5 Test Configuration

- 3.5.1 The EUT was placed on a non-conductive table whose total height equaled 80cm. The turntable can rotate 360 degree to determine the position of the maximum emission level.
- 3.5.2 The EUT was set 10 meters away from the receiving antenna that was mounted on a non-conductive mast. The antenna can move up and down between 1 to 4 meters to find out the maximum emission level.
- 3.5.3 The initial testing identified the frequency that has the highest disturbance relative to the limit while operating the EUT in typical modes of operation and cable positions in a test setup representative of typical system configuration.
- 3.5.4 The identification of the frequency of highest emission with respect to the limit was found by investigating emissions at a number of significant frequencies. The probable frequency of maximum emission had been found and that the associated cable and EUT configuration and mode of operation had been identified.

3.6 Configuration of EUT

- 3.6.1 Setup the EUT and simulates as shown section 1.3.
- 3.6.2 Turn on the power of all equipment.
- 3.6.3 Activate the Winfcc mode (1024x768)
- 3.6.4 Measure the horizontal polarization and record the value.
- 3.6.5 Change into vertical polarization and record the value.

3.7 Test Result

PASS.

The final tests data as shown on following page.

Radiated Emission Test Data

Date of Tested : 2006-10-12 Polarization : Horizontal
 Temperature : 25 Humidity : 50%
 Test Mode : Winfcc mode (1024x768)

Frequency (MHz)	Factor (dB)	Meter Reading (dBuV)	Emission Level (dBuV)	Limits (dBuV/m)	Margin (dB)
172.72	8.91	15.29	24.2	30	-5.8
303.34	13.29	18.51	31.8	37	-5.2
396.2	15.44	15.56	31	37	-6
402.52	15.92	15.48	31.4	37	-5.6
666.18	19.66	14.04	33.7	37	-3.3
753.27	21.47	9.53	31	37	-6

Remark : All readings are Quasi-Peak values.

Radiated Emission Test Data

Date of Tested : 2006-10-12 Polarization : Vertical
 Temperature : 25 Humidity : 50%
 Test Mode : Winfcc mode (1024x768)

Frequency (MHz)	Factor (dB)	Meter Reading (dBuV)	Emission Level (dBuV)	Limits (dBuV/m)	Margin (dB)
83.22	8.37	18.73	27.1	30	-2.9
114.66	8.49	17.41	25.9	30	-4.1
213.84	13.57	16.13	29.7	30	-0.3
666.18	19.66	14.34	34	37	-3
801.65	22.2	9.1	31.3	37	-5.7
813.74	22.46	9.54	32	37	-5

Remark : All readings are Quasi-Peak values.

4 Harmonic Current Emission Measurement

4.1 Instrument

Instrument	Manufacturer	Model	Serial No.	Date of Calibration
Programmable AC Source	Chroma	6520	2048	2005-05-17
Universal Power Analyzer	Chroma	6630	0597	2005-05-24

Note: All instrument upon which need to calibrated are with calibration period of 1 year.

4.2 Configuration of Instrument Setup

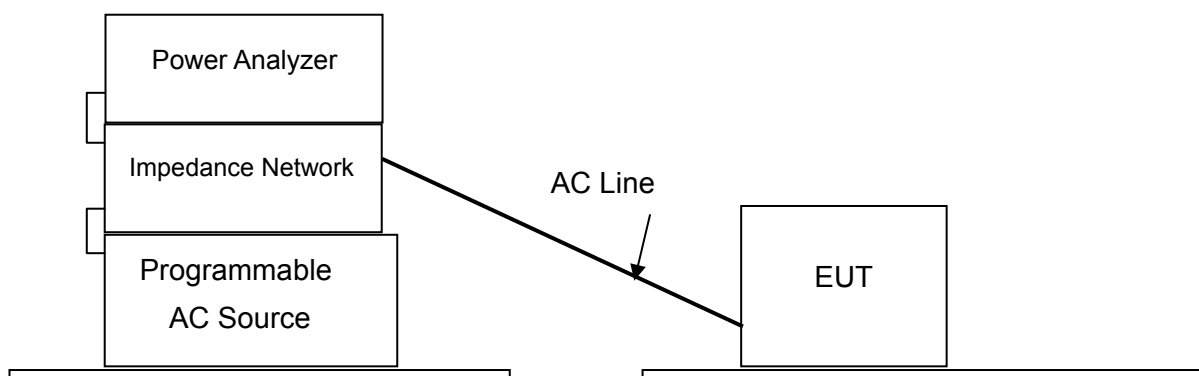

4.3 EUT Operation Condition

Environment:

Temperature	Humidity	Atmospheric Pressure
25	40%RH	1016mbar

4.4 Test Limit

Class D Equipment

Harmonics Order	Maximum Permissible Harmonic current Per watt (mA/W)	Maximum Permissible Harmonic current A
3	3.4	2.30
5	1.9	1.14
7	1.0	0.77
9	0.5	0.44
11	0.35	0.33
13 ≤ n ≤ 39 (Odd harmonics only)	3.85	See table 1

4.5 Test Configuration

- 4.5.1 The EUT with power analyzer in series and supplied from a power source with the same nominal voltage and frequency as the rated supply voltage.
- 4.5.2 Set the output of the power analyzer to the rated voltage and frequency of EUT (230V, 50Hz).
- 4.5.3 Classified the EUT class by the “check wave” form” function. The measurement was automatic performed by test software. The test result was collected and analyzed by the computer.

4.6 Configuration of EUT

- 4.6.1 Setup the EUT and simulates as shown section 1.3.
- 4.6.2 Turn on the power of all equipment.
- 4.6.3 Activate the Winfcc mode (1024x768).

4.7 Test Result

PASS.

The measured result as shown on following page.

5 Voltage Fluctuations and Flicker Measurement

5.1 Instrument

Instrument	Manufacturer	Model	Serial No.	Date of Calibration
Programmable AC Source	Chroma	6520	2048	2005-05-17
Universal Power Analyzer	Chroma	6630	0597	2005-05-24

Note: All instrument upon which need to calibrated are with calibration period of 1 year.

5.2 Configuration of Instrument Setup

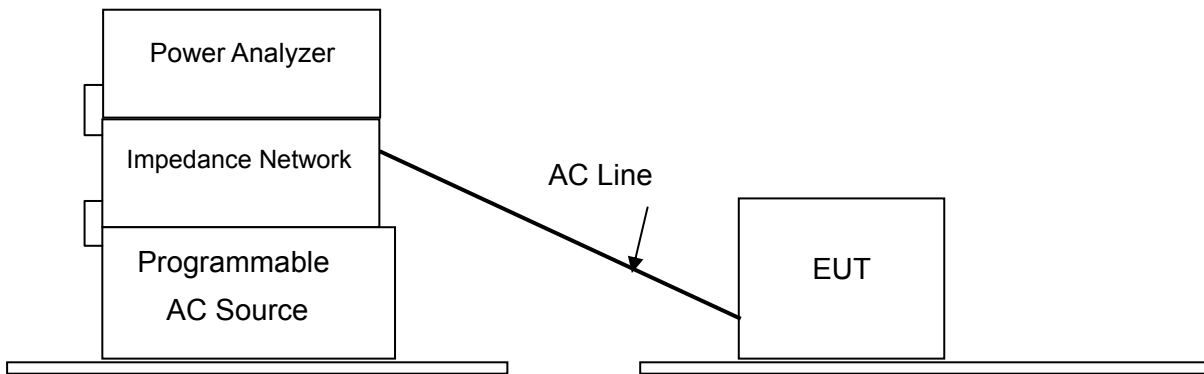

5.3 EUT Operation Condition

Environment:

Temperature	Humidity	Atmospheric Pressure
25	40%RH	1016mbar

5.4 Test Limit

The following limits apply:

- the value of P_{st} shall not be greater than 1.0;
- the value of P_{lt} shall not be greater than 0.65;
- the relative steady-state voltage change, d_c , shall not exceed 3%;
- the maximum relative voltage change, d_{max} , shall not exceed 4%;
- the value of $d(t)$ during a voltage change shall not exceed 3% for more than 200 ms.

5.5 Test Configuration

- 5.5.1 The EUT with power analyzer in series and supplied from a power source with the same nominal voltage and frequency as the rated supply voltage.
- 5.5.2 Set the output of the power analyzer to the rated voltage and frequency of EUT (230V, 50Hz).
- 5.5.3 Select the test time of observation period for short-term ($T_p = 10$ min) and long-term ($T_p = 2$ hrs).
The test result was collected and analyzed by the computer.

5.6 Configuration of EUT

- 5.6.1 Setup the EUT and simulates as shown section 1.3.
- 5.6.2 Turn on the power of all equipment.
- 5.6.3 Activate the Winfcc mode (1024x768).

5.7 Test Result

PASS.

The measured result as shown on following page.



ANALYZER 6630

2006.10.11 18:12:54

Extreme Flicker-I M1

Note:

Numerical Reference Impedance
U: 230.5 V I: 0.055 A f: 50.000 Hz PF: 0.345

EVALUATION:-----

Type of observation period	Short	Long	Limit
Observation time	1	10 min	
Maximum relative voltage change	dmax:	0.00 %	4
Max rel steady state voltage change	dc :	0.00 %	3
Duration of d(t) > 3 %	t :	0.00 s	0.2
Short term flicker severity	Pst :	0.00	1.00
Long term flicker severity	Plt :	---	0.65

Based on 10 (10) short term cycles

PASSED

Measurement completed

Appl: CLASS D

(1311_00)

Next measure

Extreme time graph

Change to histogram

Write to disk

Select module



ANALYZER 6630

2006.10.11 18:13:45

Extreme Flicker-I M1

Note:

Numerical Reference Impedance
U: 230.5 V I: 0.055 A f: 50.000 Hz PF: 0.345

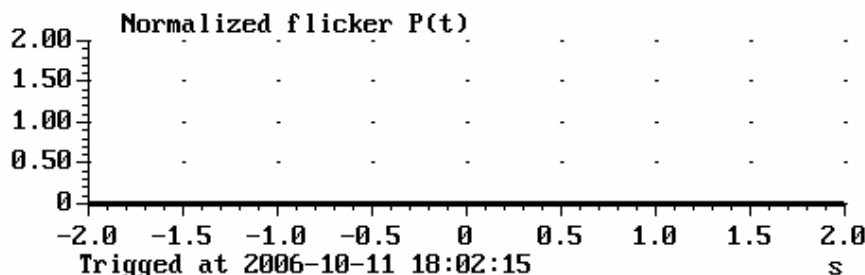
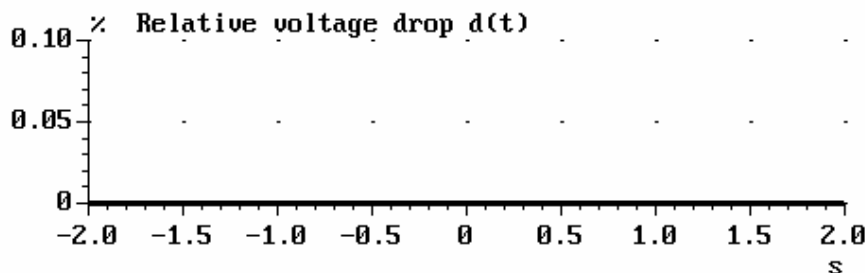

Appl: CLASS D

(133_00)

Next measure

Change to table

Refresh time graph

Write to disk

Select module



6 Electrostatic Discharge Immunity Test

6.1 Instrument

Instrument	Manufacturer	Model	Serial No.	Date of Calibration
ESD Mouse Box	EMC PARTNER	ESD MOUSE	ESD101-301	2005-08-01
TRANSIENT 2000	EMC PARTNER	TRA-2000	449	2005-08-01

Note: All instrument upon which need to calibrated are with calibration period of 1 year.

6.2 Configuration of Instrument Setup

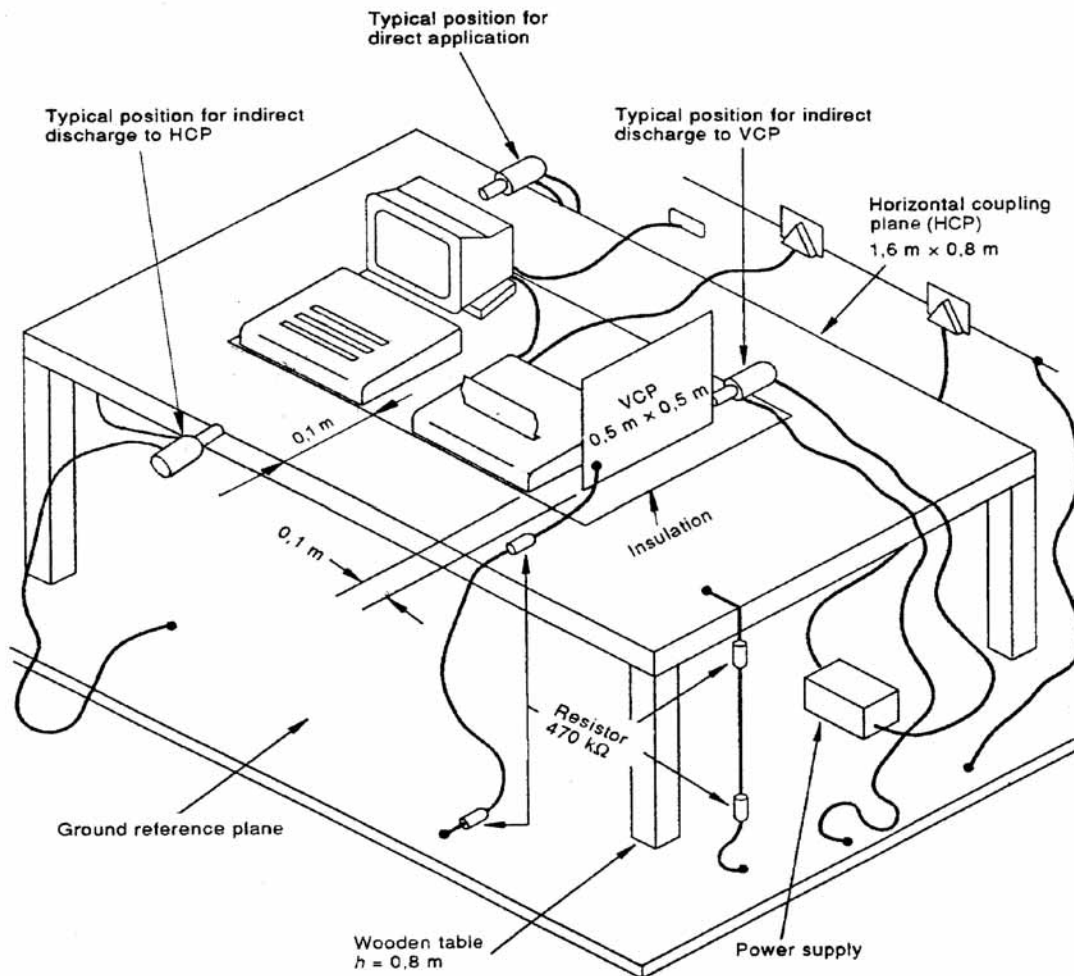

6.3 Test Levels

Level	Contact discharge (kV)	Air discharge (kV)
1	±2	±2
2	±4	±4
3	±6	±8
4	±8	±15
X	Special	Special

6.4 Test Configuration

- 6.4.1 For Table-top equipment, the test set-up shall consist of a wooden table, 0.8 m high, standing on the ground reference plane.
- 6.4.2 Contact discharges to the conductive surfaces and coupling planes:
The EUT shall be exposed at least 200 discharges, 100 each at negative and positive polarity, at a minimum of four test points (a minimum of 50 discharges at each point). One of the test points shall be subjected to at least 50 indirect discharges (contact) to the center of the front edge of the horizontal coupling plane. The remaining three test points shall each receive at least 50 direct contact discharges. If no direct contact test points are available, then at least 200 indirect discharges shall be applied in the indirect mode (see IEC 61000-4-2: 2001 for use of the Vertical Conducting Plane (VCP)). Tests shall be performed at a maximum repetition rate of one discharge per second.
- 6.4.3 Air discharge at insulating surfaces:
There were minimum of 10 single air discharges to the selected test point.
- 6.4.4 The selected points, performed with electrostatic discharge were marked with red labels on the EUT. The ESD generator (gun) was held perpendicular to the surface to which the discharge was applied.

6.5 Configuration of EUT

- 6.5.1 Setup the EUT and simulates at section 1.3.
- 6.5.2 Turn on the power of all equipment.
- 6.5.3 Activate the Winfcc mode (1024x768).
- 6.5.4 Operating condition was observed by test engineer.

6.6 Test Requirement

- 6.6.1 Air discharge: ± 8 kV
- 6.6.2 Contact discharge: ± 4 kV
- 6.6.3 HCP discharge: ± 4 kV
- 6.6.4 VCP discharge: ± 4 kV
- 6.6.5 Performance criterion: B

6.7 Test Result

6.7.1 Environment Condition :

Temperature	Humidity	Atmospheric Pressure
25	40%RH	1016mbar

6.7.2 Observation of direct discharge

Test points: 1. Surface of case. 2. Junction of case. 3. Screw.
4. Button. 5. VGA Port. 6. USB Port. 7. PS2 Port.

Type of Discharge	Test Specification				Performance required by EN55024	Observed Result	Verdict
	Test Level	Polarity	Test Point	Number of discharge			
Air Discharge	2,4,8 (KV)	±	1~7	10/ per point	B	A	Pass
Contact Discharge	2,4 (KV)	±	1,3~7	50/ per point	B	A	Pass
Remark: 1. No temporary degradation or less of function has been observed through out the entire time interval of air discharge. 2. No temporary degradation or less of function has been observed through out the entire time interval of contact discharge.							
Note: The selected points were marked with red labels on the EUT.							

6.7.3 Observation of indirect discharge

Test points: 1. Front side. 2. Rear side. 3. Left side. 4. Right side.

Type of Discharge	Test Specification				Performance required by EN55024	Observed Result	Verdict
	Test Level	Polarity	Test Point	Number of discharge			
HCP application	2,4 (KV)	±	1~4	50/ per point	B	A	Pass
VCP application	2,4 (KV)	±	1~4	50/ per point	B	A	Pass
Remark: 1. No temporary degradation or less of function has been observed through out the entire time interval of HCP application. 2. No temporary degradation or less of function has been observed through out the entire time interval of VCP application.							
Note: The selected points were marked with red labels on the EUT.							

PASS

The test result shows that the EUT compliant with the test requirement specified in EN 55024:1998/ A1:2001/ A2:2003.

7 Radio-frequency, Electromagnetic field Immunity Test

7.1 Instrument

Instrument	Manufacturer	Model	Serial No.	Date of Calibration
Signal Generator	HP	8648C	N/A	2005-11-22
Power Amplifier	IFI	CMX50	N/A	2005-10-15
Field Probe	EMCO	7201	N/A	2005-10-05
Power Antenna	EMCO	3142	N/A	2005-10-15

Note: All instrument upon which need to calibrated are with calibration period of 1 year.

7.2 Configuration of Instrument Setup

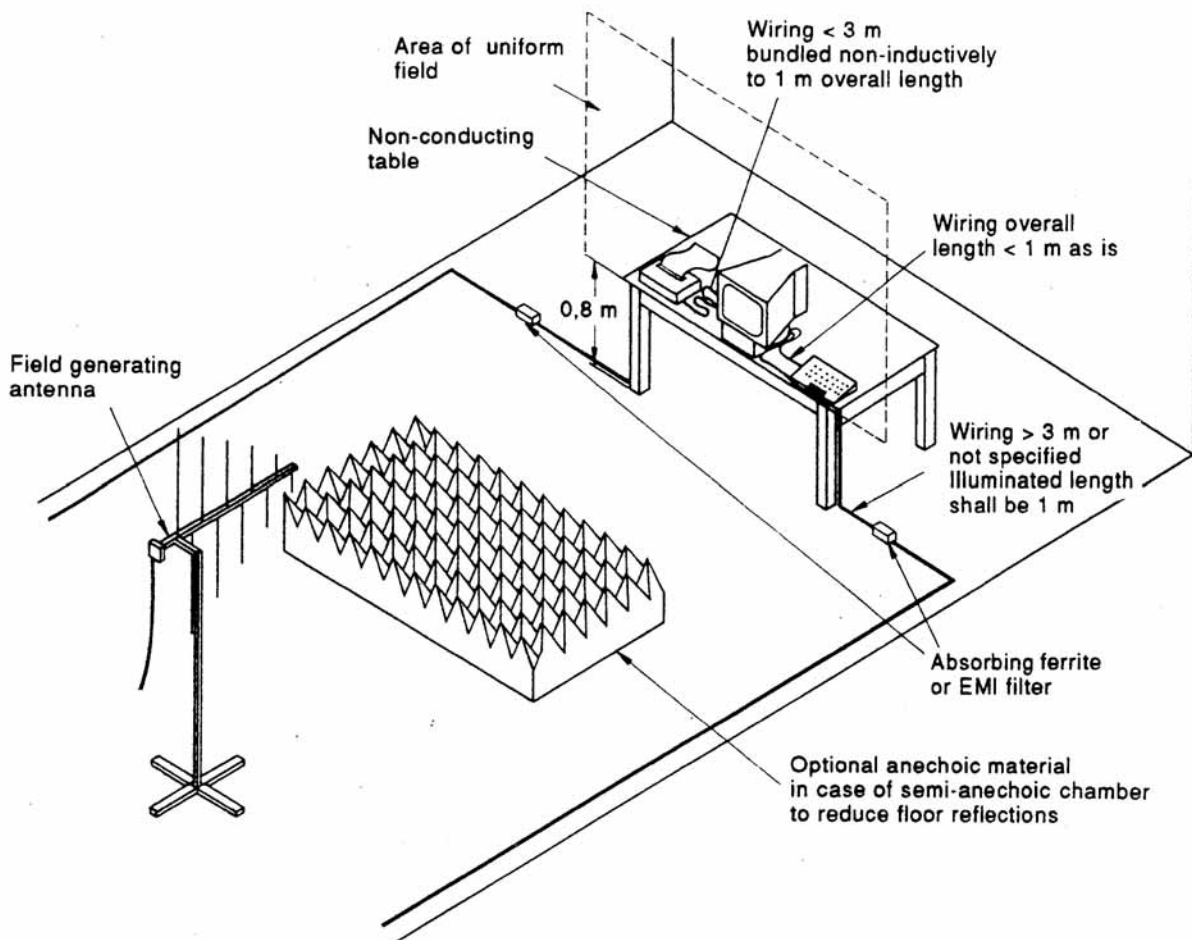

7.3 Test Level

Level	Test field strength (V/m)
1	1
2	3
3	10
X	Special

7.4 Test Configuration

- 7.4.1 Before testing, the intensity of the established field strength was checked by placing the field sensor at a calibration grid point, and with the field generating antenna and cables in the same positions as used for the calibration, the forward and reverse power were measured. The forward power needed to give the calibrated field was evaluated.
- 7.4.2 After the calibration had been verified, the test field was then generated using the values obtained from the calibration. The EUT and the auxiliary equipment were placed on a table with 0.8 meters height. The EUT was initially placed with one face coincidence with the calibration plane at a distance of 3 meters away from the illuminating antenna (the same as used for the field calibration). Both horizontal and vertical polarizations of the antenna and four sides of the EUT were set for the radiated field immunity test.
- 7.4.3 In order to survey the performance of the EUT, a CCD camera was used to monitor the EUT performance.

7.5 Configuration of EUT

- 7.5.1 Setup the EUT and simulates as shown section 1.3.
- 7.5.2 Turn on the power of all equipment.
- 7.5.3 Activate the Winfcc mode (1024x768).
- 7.5.4 Operating condition was observed by test engineer.

7.6 Test Result

7.6.1 Environment

Temperature	Humidity	Atmospheric Pressure
25	40%RH	1016mbar

7.6.2 Observation of test

Type of modulation	Test Specification			Performance required by EN55024	Observed Result	Verdict
	Field strength	Frequency range	Modulation			
Amplitude modulation	3V/m	80 to 1000MHz	80%, 1KHz, sinusoidal	A	A	PASS
Remark:	No temporary degradation or less of function has been observed through out the entire time interval of the test.					
Note:	The selected points were marked with red labels on the EUT.					

PASS

The test result shows that the EUT compliant with the test requirement specified in EN 55024:1998/ A1:2001/ A2:2003.

8 Electrical Fast Transient/Burst Immunity Test

8.1 Instrument

Instrument	Manufacturer	Model	Serial No.	Date of Calibration
TRANSIENT 2000	EMC PARTNER	TRA-2000	449	2005-08-01

Note: All instrument upon which need to calibrated are with calibration period of 1 year.

8.2 Configuration of Instrument Setup

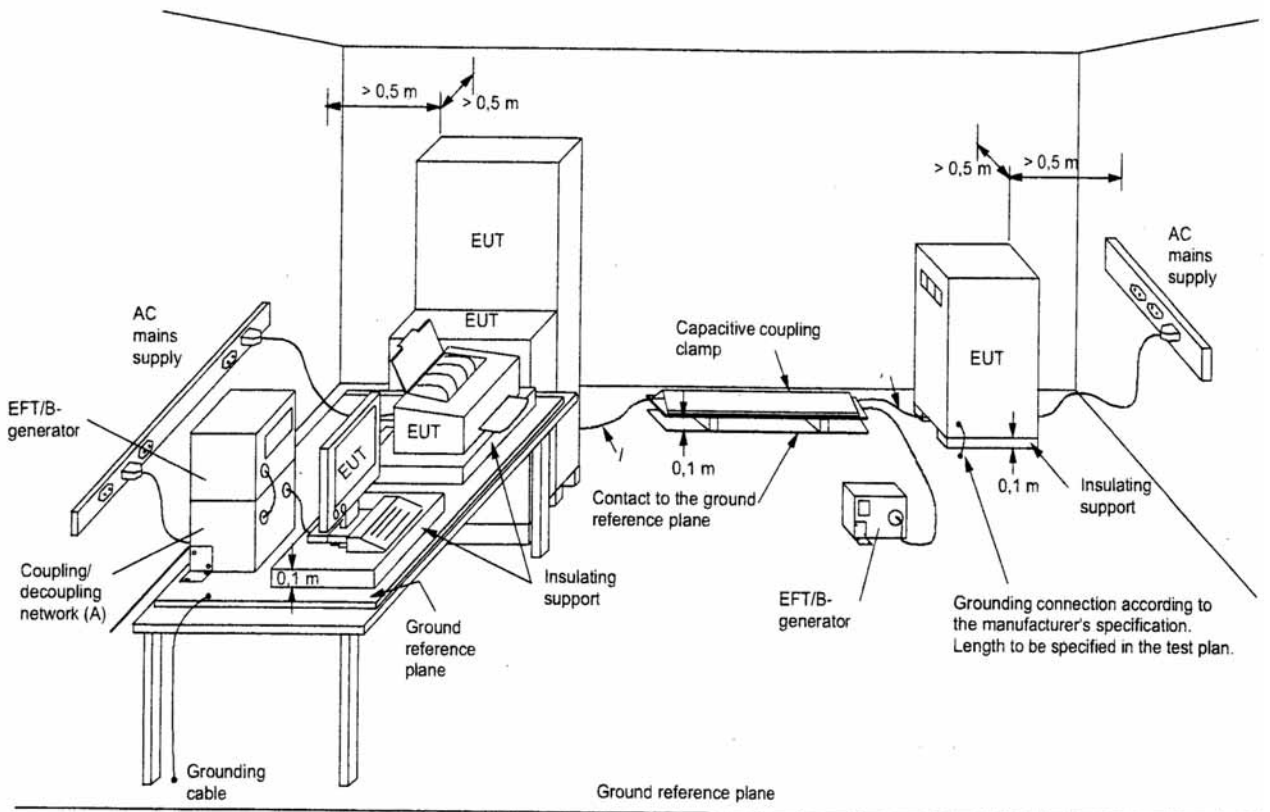

8.3 Test Level

Level	On power supply port, PE		On I/O signal, data and control ports	
	Voltage Peak (kV)	Repetition rate (kHz)	Voltage Peak (kV)	Repetition rate (kHz)
1	±0.5	5	±0.25	5
2	±1	5	±0.5	5
3	±2	5	±1	5
4	±4	2.5	±2	5
X	Special	Special	Special	Special

8.4 Test Configuration

8.4.1 The EUT and the auxiliary equipment were placed on a wooden table of 0.8 meters height. The size of ground plane is greater than 1m x1m and project beyond the EUT by at least 0.1m on all

sides. The ground plane is connected to the protective earth.

8.4.2 The EUT was connected to the power mains through a coupling device that directly couples the EFT interference signal. Each of the Line, Neutral and Protective Earth (PE) conductors was impressed with burst noise for 1 minute. Both the voltage polarities were applied for each test level. The length of power cord between the coupling device and the EUT was less than 1 meter.

8.5 Configuration of EUT

8.5.1 Setup the EUT and simulates as shown section 1.3.

8.5.2 Turn on the power of all equipment.

8.5.3 Activate the Winfcc mode (1024x768).

8.5.4 Operating condition was observed by test engineer.

8.6 Test Result

8.6.1 Environment

Temperature	Humidity	Atmospheric Pressure
25	40%RH	1016mbar

8.6.2 Observation of power supply port

Inject Line	Test Specification				Performance required by EN 55024	Observed Result	Verdict (Pass/Fail)
	Voltage (KV)	Test Duration (Sec)	Repetition Rate (kHz)	Tr/ Td (nS)			
L	±1	60	5	5/50	B	B	PASS
N	±1	60	5	5/50	B	B	PASS
PE	±1	60	5	5/50	B	N/A	N/A
L + N	±1	60	5	5/50	B	B	PASS
L + PE	±1	60	5	5/50	B	N/A	N/A
N + PE	±1	60	5	5/50	B	N/A	N/A
L + N +PE	±1	60	5	5/50	B	N/A	N/A

Remark: While the burst applied, the following condition was observed:
Screen disturbance occurred during the test. After the test, the EUT has recovered itself.

Note: Phase shifting:0°,90°,180°,270°,360°

8.6.3 Observation of I/O, communication ports (Applicable only to cable length >3m)

There is no I/O and communication cable greater than 3 meters long; therefore, no test has been required.

PASS

The test result shows that the EUT compliant with the test requirement specified in EN 55024:1998/ A1:2001/ A2:2003.

9 Surge Immunity Test

9.1 Instrument

Instrument	Manufacturer	Model	Serial No.	Date of Calibration
TRANSIENT 2000	EMC PARTNER	TRA-2000	449	2005-08-01

Note: All instrument upon which need to calibrated are with calibration period of 1 year.

9.2 Configuration of Instrument Setup

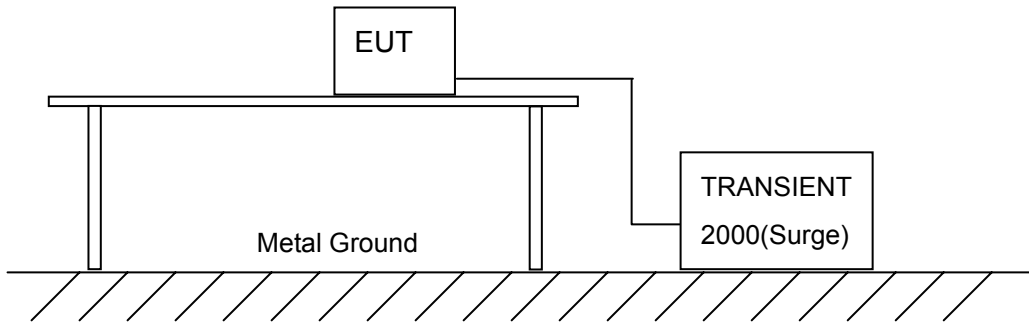

9.3 Test Level

Level	Open-circuit test voltage (kV)
1	±0.5
2	±1.0
3	±2.0
4	±4.0
X	Special

9.4 Test Configuration

- 9.4.1 The EUT and the auxiliary equipment were placed on a table of 0.8m heights above a metal ground reference plane. The size of ground plane is greater than 1m x1m and project beyond the EUT by at least 0.1m on all sides. The ground plane is connected to the protective earth. The length of power cord between the coupling device and the EUT was less than 2 meters (provided by the manufacturer).
- 9.4.2 The EUT was connected to the power mains through a coupling device that directly couples the Surge interference signal. The surge noise was applied synchronized to the voltage phase at the zero crossing and the peak value of the AC voltage wave (positive and negative).
- 9.4.3 The surges were applied line to line and line(s) to earth. When testing line to earth the test voltage was applied successively between each of the lines and earth. Steps up to the test level specified increased the test voltage. All lower levels including the selected test level were tested.

The polarity of each surge level included positive and negative test pulses.

9.5 Configuration of EUT

- 9.5.1 Setup the EUT and simulates as shown section 1.3.
- 9.5.2 Turn on the power of all equipment.
- 9.5.3 Activate the Winfcc mode (1024x768).
- 9.5.4 Operating condition was observed by test engineer.

9.6 Test Result

9.6.1 Environment

Temperature	Humidity	Atmospheric Pressure
25	40%RH	1016mbar

9.6.2 Observation of power supply port

Inject Line	Test Specification			Performance required by EN 55024	Observed Result	Verdict (Pass/Fail)
	Voltage (KV)	Min. of surge at each polarity	Repetition Rate (per min)			
L + N	±0.5, 1	5	1	B	A	PASS
L + PE	±0.5, 1,2	5	1	B	N/A	N/A
N + PE	±0.5, 1, 2	5	1	B	N/A	N/A

Remark: No temporary degradation or less of function has been observed through out the entire time interval of the test.

Note: Phase shifting:0°,90°,180°,270°,360°

9.6.3 Observation of other supply/ signal lines: (Applicable only to ports which according to the manufacturer’s specification may connect directly to outdoor cables.)

N/A

PASS

The test result shows that the EUT compliant with the test requirement specified in EN 55024:1998/ A1:2001/ A2:2003.

10 Radio-frequency, Conducted Disturbances Immunity Test

10.1 Instrument

Instrument	Manufacturer	Model	Serial No.	Date of Calibration
CDN	FRANKONIA	CDN M2+M3	A3011037	2005-08-02
C.I. TEST SYSTEM	FRANKONIA	CIT-10/75	102C3208	2005-08-02
POWER METER	FRANKONIA	75-A-FFN-06	0212	N/A
RF CABLE	N/A	N/A	N/A	2005-03-14

Note: All instrument upon which need to calibrated are with calibration period of 1 year.

10.2 Configuration of Instrument Setup

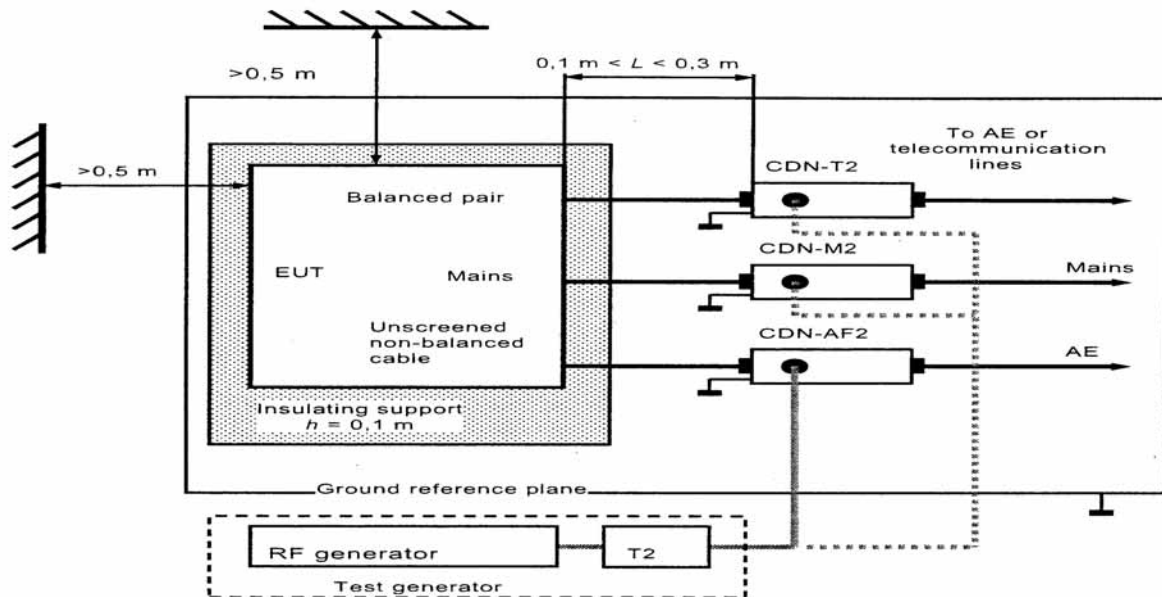

10.3 Test Level

Level	Voltage Level (V)
1	1
2	3
3	10
X	Special

10.4 Test Configuration

10.4.1 The EUT was placed on a table of 0.1 m height.

10.4.2 The EUT was connected to the power mains through a Coupling and Decoupling Networks (CDN).

10.4.3 The test was performed with the test generator connected to each of the coupling and decoupling

devices in turn while the other non-excited RF input ports of the coupling devices were terminated by a 50 Ω terminator.

10.4.4 The frequency range was swept from 150kHz to 80MHz.using the signal levels established during the setting process, and without the disturbance signal 80% amplitude modulated with a 1 kHz sine wave, pausing to adjust the RF signal level or to switch coupling devices as necessary. The rate of sweep was less than 1.5×10^{-3} decades/s. And the step size of the frequency sweep was also less than 1% of the start and thereafter 1% of the preceding frequency value. The dwell time at each frequency was more than the time necessary for the EUT to be excited, and able to respond.

10.5 Configuration of EUT

- 10.5.1 Setup the EUT and simulates as shown section 1.3.
- 10.5.2 Turn on the power of all equipment.
- 10.5.3 Activate the Winfcc mode (1024x768).
- 10.5.4 Operating condition was observed by test engineer.

10.6 Test Result

10.6.1 Environment:

Temperature	Humidity	Atmospheric Pressure
25	40%RH	1016mbar

10.6.2 Observation of test

Type of modulation	Test Specification			Performance required by EN 55024	Observed Result	Verdict
	Voltage Level (emf) U_0	Frequency range	Modulation			
Amplitude modulation	3V/ 130dBμV	0.15 to 80MHz	80%, 1KHz, sinusoidal	A	A	PASS
Remark:	No temporary degradation or less of function has been observed through out the entire time interval of the test.					
Note:	Phase shifting:0°,90°,180°,270°,360°					

PASS

The test result shows that the EUT compliant with the test requirement specified in EN 55024:1998/ A1:2001/ A2:2003.

11 Voltage Dips, Short Interruptions Immunity Test

11.1 Instrument

Instrument	Manufacturer	Model	Serial No.	Date of Calibration
TRANSIENT 2000	EMC PARTNER	TRA-2000	449	2005-08-01

Note: All instrument upon which need to calibrated are with calibration period of 1 year.

11.2 Configuration of Instrument Setup

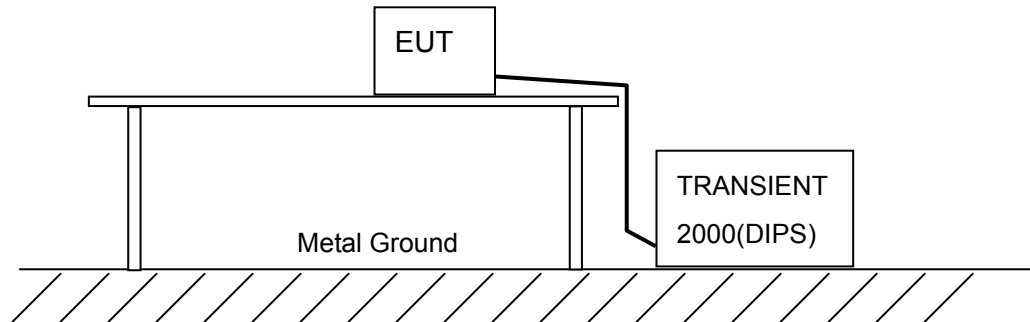

11.3 Test Level

Level (% U_T)	Voltage dip & short interruptions (% U_T)	Duration (in period)
0	100	0.5
		1
40	60	5
		10
		25
70	30	50
		x

11.4 Test Configuration

- 11.4.1 The power cord was used as supplied by the manufacturer. The EUT was connected to the line output of the Voltage Dips and Interruption Generator.
- 11.4.2 The EUT was tested for () 95% voltage dip of supplied voltage with a duration of 10ms, () 30% voltage dip of supplied voltage and duration 500ms. Both of the dip tests were carried out for a sequence of three voltage dips with intervals of 10 seconds.
- 11.4.3 A 95% voltage interruption of supplied voltage with duration of 5000ms was followed, which was a sequence of three voltage interruptions with intervals of 10 seconds.
- 11.4.4 Voltage reduction was controlled at 0°, 90° and 270° of the voltage phase angle. The

performance of the EUT was checked after the voltage dip or interruption.

11.5 Configuration of EUT

- 11.5.1 Setup the EUT and simulates as shown section 1.3.
- 11.5.2 Turn on the power of all equipment.
- 11.5.3 Activate the Winfcc mode (1024x768).
- 11.5.4 Operating condition was observed by test engineer.

11.6 Test Result

11.6.1 Environment Condition :

Temperature	Humidity	Atmospheric Pressure
25	40%RH	1016mbar

11.6.2 Observation of power supply port

11.6.2.1 Voltage dips

Voltage reduction (%)	Test Specification			Performance required by EN 55024	Observed Result	Verdict (Pass/Fail)
	No. of periods	No. of reductions at each duration	Interval between duration (sec.)			
>95	0.5	3	≥ 10	B	A	Pass
30	25	3	≥ 10	C	A	Pass
Remark	No temporary degradation or less of function has been observed through out the entire time interval of the test. No temporary degradation or less of function has been observed through out the entire time interval of the test. Note: The voltage changes occur at 0° crossover point(Phase shifting:0°,180°,360°)					

11.6.2.2 Voltage interruption

Voltage reduction (%)	Test Specification			Performance required by EN 55024	Observed Result	Verdict (Pass/Fail)
	No. of periods	No. of reductions at each duration	Interval between duration (sec.)			
>95	250	3	≥ 10	C	A	Pass
Remark:	No temporary degradation or less of function has been observed through out the entire time interval of the test. Note: The voltage changes occur at 0° crossover point(Phase shifting:0°,180°,360°)					

PASS

The test result shows that the EUT compliant with the test requirement specified in EN 55024:1998/ A1:2001/ A2:2003.

12 Photographs of Test

12.1 Power Line Conducted Test



Front View

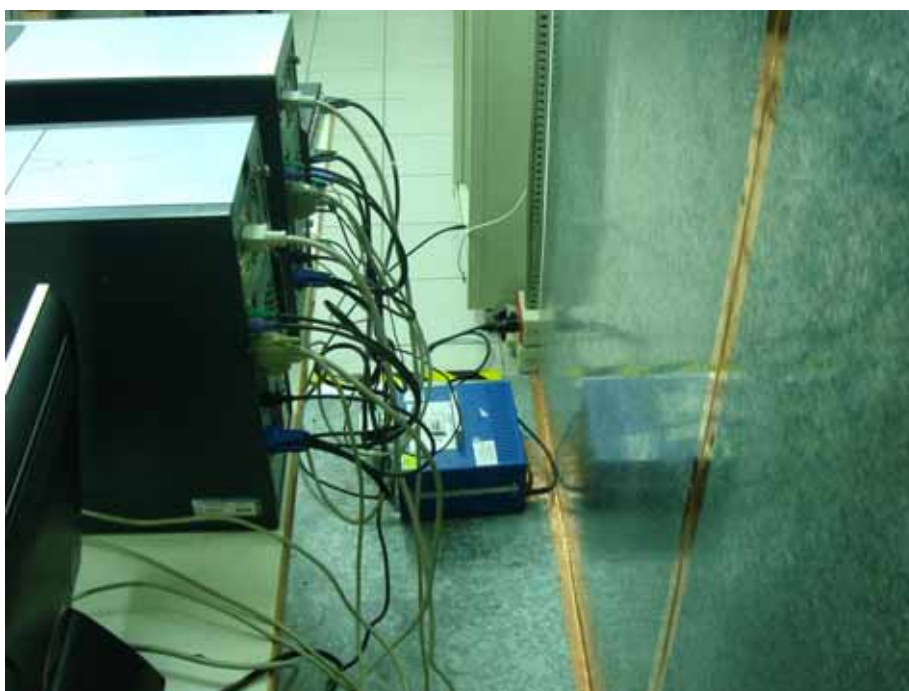

Rear View

12.2 Radiated Emission Test

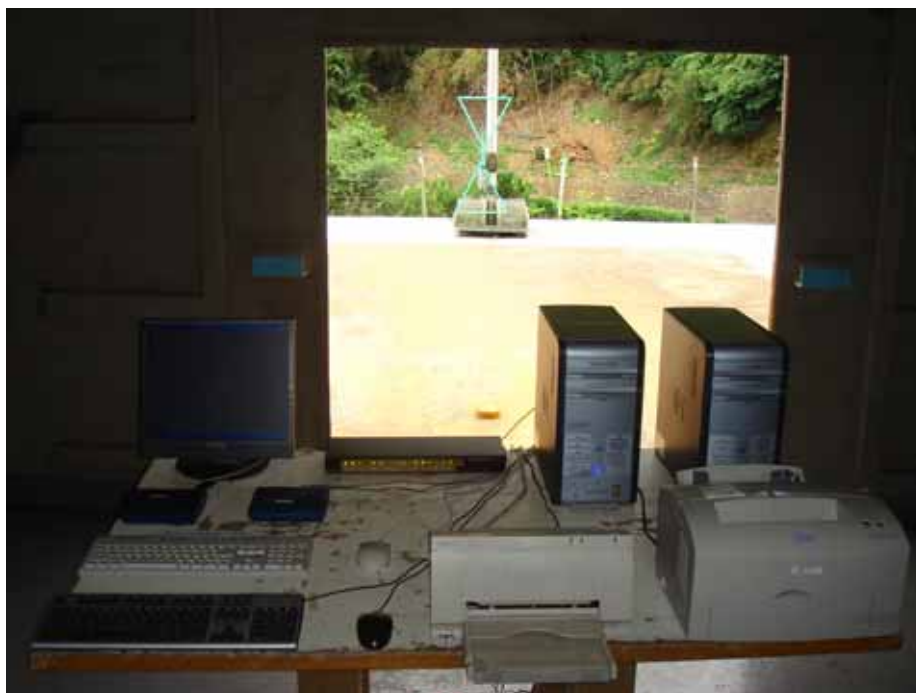

Front View

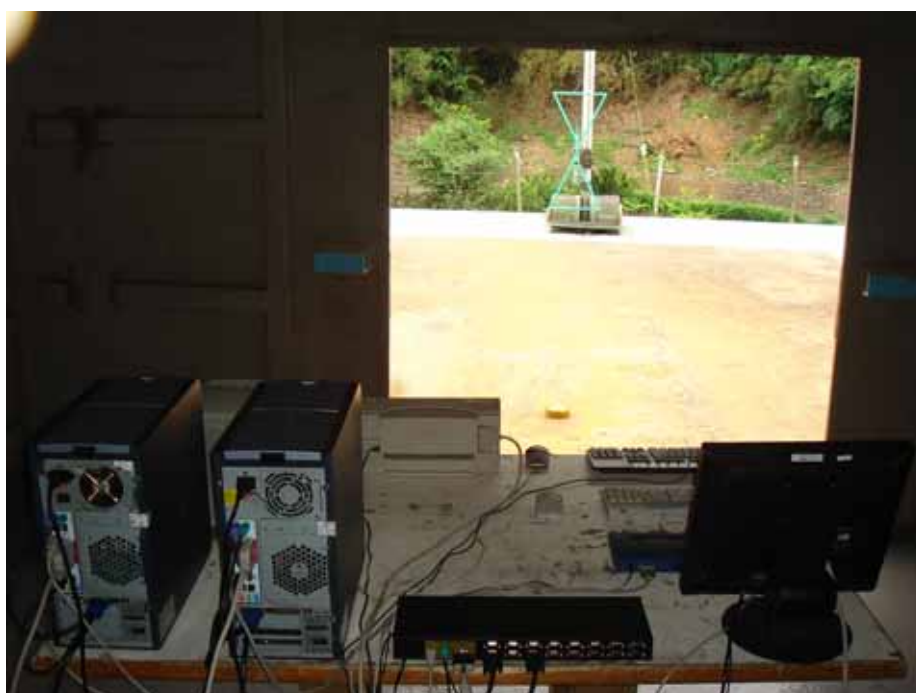

Rear view

12.3 Harmonic current & Voltage Fluctuations and Flicker Measurement



12.4 Electrostatic Discharge Immunity Test



12.5 Electrical Fast Transient/Burst Immunity Test



12.6 Surge immunity Test



12.7 Radio-frequency, Conducted Disturbances Immunity Test



12.8 Voltage Dips, Short Interruptions Immunity Test



13 Photographs of EUT



Front View of EUT



Rear View of EUT



Inside view of EUT



Front view of EUT's PCB1-1

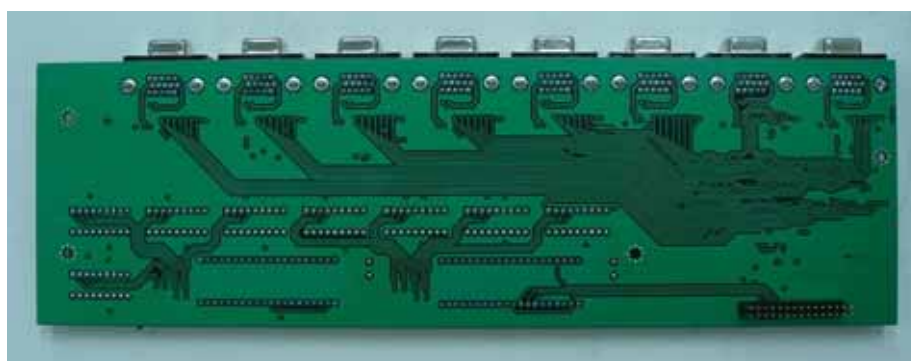

Rear view of EUT's PCB 1-2



Front view of EUT's PCB 2-1

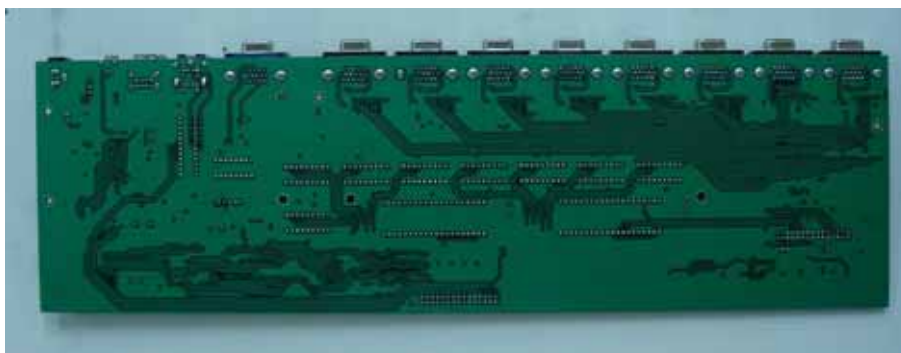

Rear view of EUT's PCB 2-2



Front view of EUT's PCB 3-1



Rear view of EUT's PCB 3-2



View of EUT's VGA Cable



View of EUT's Adaptor

14 Photographs of ESD Test Point



View of ESD test point



View of ESD test point



View of ESD test point

Appendix 1 – Conducted Emission Test Waveform

A1.1 Mode : Winfcc mode(1024x768)

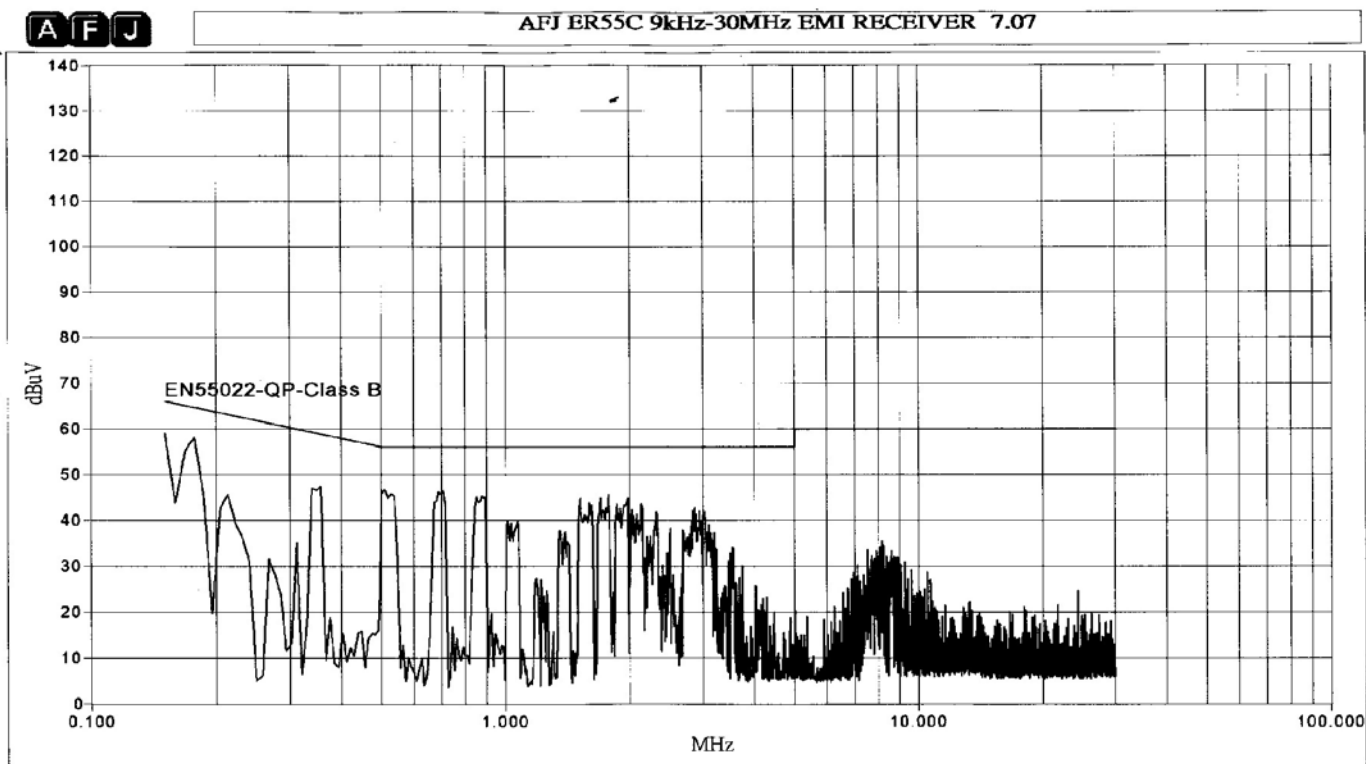

Line

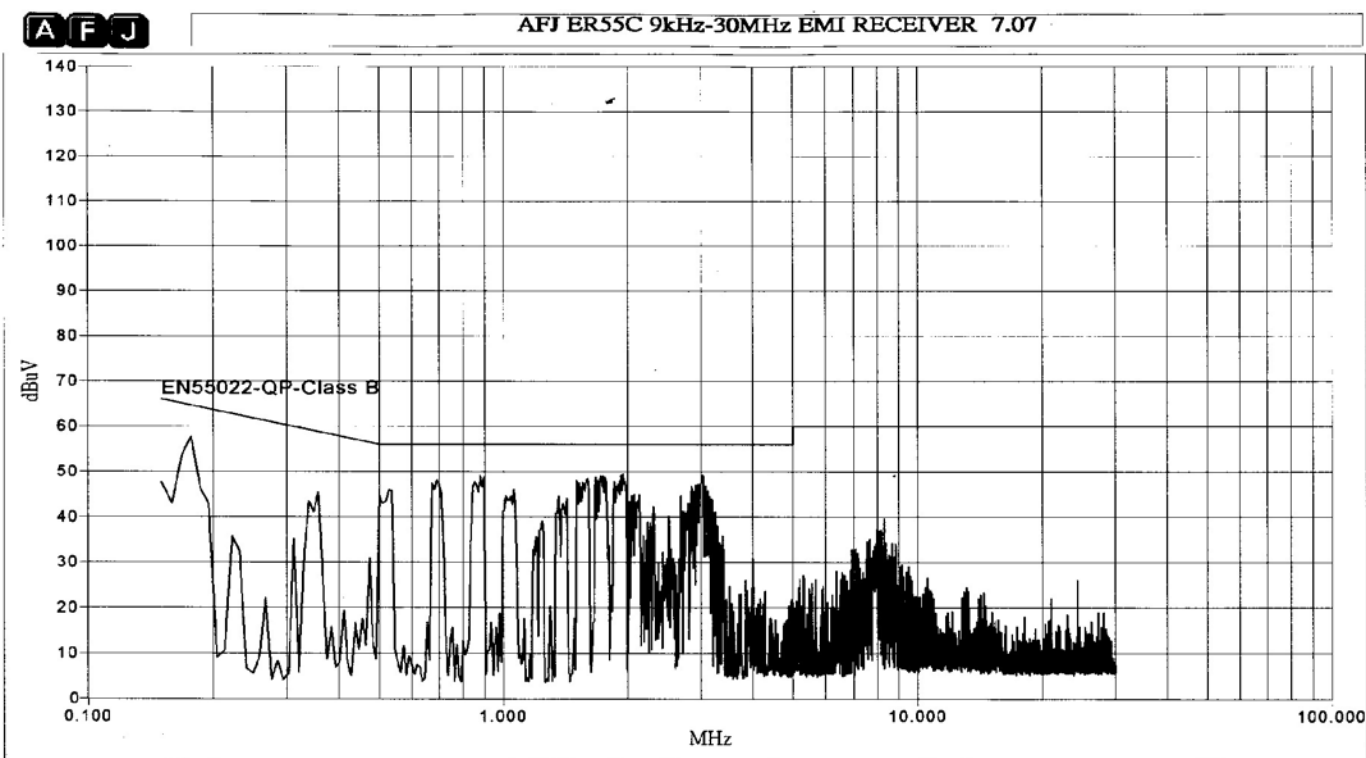

Neutral